

DigTech

STUDIO VOCALIST EX

VOCAL HARMONY PROCESSOR

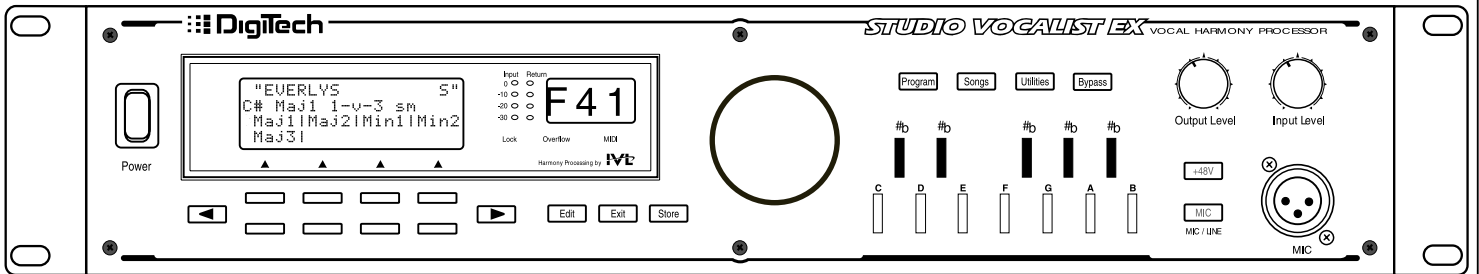

OWNERS MANUAL • • • _____

EX Version 1.10



The symbols shown above are internationally accepted symbols that warn of potential hazards with electrical products. The lightning flash with arrowpoint in an equilateral triangle means that there are dangerous voltages present within the unit. The exclamation point in an equilateral triangle indicates that it is necessary for the user to refer to the owner's manual.

These symbols warn that there are no user serviceable parts inside the unit. Do not open the unit. Do not attempt to service the unit yourself. Refer all servicing to qualified personnel. Opening the chassis for any reason will void the manufacturer's warranty. Do not get the unit wet. If liquid is spilled on the unit, shut it off immediately and take it to a dealer for service. Disconnect the unit during storms to prevent damage.

U.K. MAINS PLUG WARNING

A moulded mains plug that has been cut off from the cord is unsafe. Discard the mains plug at a suitable disposal facility. NEVER UNDER ANY CIRCUMSTANCES SHOULD YOU INSERT A DAMAGED OR CUT MAINS PLUG INTO A 13 AMP POWER SOCKET. Do not use the mains plug without the fuse cover in place. Replacement fuse covers can be obtained from your local retailer. Replacement fuses are 13 amps and MUST be ASTA approved to BS1362.

ELECTROMAGNETIC COMPATIBILITY

This unit conforms to the Product Specifications noted on the Declaration of Conformity. Operation is subject to the following two conditions:

- this device may not cause harmful interference, and
- this device must accept any interference received, including interference that may cause undesired operation. Operation of this unit within significant electromagnetic fields should be avoided.
- use only shielded interconnecting cables.

FCC COMPLIANCE

This equipment has been tested and found to comply with the limits for a Class B digital device, pursuant to Part 15 of the FCC Rules. These limits are designed to provide reasonable protection against harmful interference in a residential installation. This equipment generates, uses and can radiate radio frequency energy and, if not installed and used in accordance with the instructions, may cause harmful interference to radio communications. However, there is no guarantee that interference will not occur in a particular installation. If this equipment does cause harmful interference to radio or television reception, which can be determined by turning the equipment off and on, the user is encouraged to try to correct the interference by one or more of the following measures:

- Reorient or relocate the receiving antenna
- Increase the separation between the equipment and receiver that may cause undesired operation.
- Connect the equipment into an outlet on a circuit different from that to which the receiver is connected
- Consult the dealer or an experienced radio/TV technician for help.

DECLARATION OF CONFORMITY

Manufacturer's Name: IVL Technologies Ltd.
per DigiTech specifications
Manufacturer's Address: 6710 Bertram Place
Victoria, B.C.
Canada V8M 1Z6
declares that the products: DigiTech Studio Vocalist EX Harmony Processor

conform to the following product specifications:

Safety: EN 60065 EMC: EN 55022 (1987):
IEC 65 (1993) CISPR 22 (1993) Class B
Amendment 1 (1987) EN 50082-1 (1992)
Amendment 2 (1989)
Amendment 3 (1992)

Supplementary Information:

The product herewith complies with the requirements of the Low Voltage Directive 73/23/EEC and the EMC Directive 89/336/EEC (1989) as amended by the CE Marking Directive 93/68/EEC (1993).

IVL Technologies Ltd.
6710 Bertram Place
Victoria, B.C.
Canada V8M 1Z6
February 26, 1996

Peter George, Vice President of Engineering

European Contact: Your local DigiTech Sales and Service Office or
International Sales Office
3 Overlook Drive Unit #4
Amherst, New Hampshire 03031, USA Tel (603) 672-4244 Fax (603) 672 4246

WARNING

FOR YOUR PROTECTION, PLEASE READ THE FOLLOWING:

Water and Moisture: Appliance should not be used near water (e.g. near a bathtub, washbowl, kitchen sink, laundry tub, in a wet basement, or near a swimming pool, etc). Care should be taken so that objects do not fall and liquids are not spilled into the enclosure through openings.

POWER SOURCES: The appliance should be connected to a power supply only of the type described in the operating instructions or as marked on the appliance.

GROUNDING OR POLARIZATION: Precautions should be taken so that the grounding or polarization means of an appliance is not defeated.

POWER CORD PROTECTION: Power supply cords should be routed so that they are not likely to be walked on or pinched by items placed upon or against them, paying particular attention to cords at plugs, convenience receptacles, and the point where they exit from the appliance.

SERVICING: To reduce the risk of fire or electric shock, the user should not attempt to service the appliance beyond that described in the operating instructions. All other servicing should be referred to qualified service personnel.

CAUTION: To reduce the risk of fire replace only with same type fuse. ATTENTION: Utiliser un fusible de recharge de même type.

CAUTION: To reduce the risk of fire replace LAMP with manufacturers recommended part (Refer to service literature)

SAFETY INSTRUCTIONS

Notice For Customers If Your Unit Is Equipped With A Power Cord.

WARNING: THIS APPLIANCE MUST BE EARTHED.

The cores in the mains lead are coloured in accordance with the following code:

GREEN and YELLOW - Earth White - Neutral Black - Live

As colours of the cores in the mains lead of this appliance may not correspond with the coloured markings identifying the terminals in your plug, proceed as follows:

- The core which is coloured green and yellow must be connected to the terminal in the plug marked with the letter E, or with the earth symbol, or coloured green, or green and yellow.
- The core which is coloured white must be connected to the terminal marked N or coloured black.
- The core which is coloured black must be connected to the terminal marked L or coloured red.

This equipment may require the use of a different line cord, attachment plug, or both, depending on the available power source at installation. Connect this equipment only to the power source indicated on the equipment rear panel. If the attachment plug needs to be changed, refer servicing to qualified service personnel who should refer to the table below. The green/yellow wire shall be connected directly to the unit's chassis.

CONDUCTOR		WIRE COLOUR	
		Normal	Alt.
L	LIVE	BROWN	BLACK
N	NEUTRAL	BLUE	WHITE
E	EARTH GND	GREEN/YEL	GREEN

WARNING: If the ground is defeated, certain fault conditions in the unit or in the system to which it is connected can result in full line voltage between chassis and earth ground. Severe injury or death can then result if the chassis and earth ground are touched simultaneously.

LITHIUM BATTERY WARNING

CAUTION! This product contains a lithium battery. There is danger of explosion if battery is incorrectly replaced. Replace only with an Eveready CR2032 or equivalent. Make sure the battery is installed with the correct polarity. Discard used batteries according to manufacturer's instructions.

ADVARSEL! Lithiumbatteri - Eksplosjonsfare. Ved utskifting benyttes kun batteri som anbefalt av apparatfabrikanten. Brukt batteri returneres apparatleverandøren.

ADVARSEL! Lithiumbatteri - Eksplosjonsfare ved feilagtig håndtering. Utskiftning må kun ske med batteri av samme fabrikat og type. Levér det brukte batteri tilbake til leverandøren.

AROUTUS! Paristo voi räjähtää, jos se on virheellisesti asennettu. Vaihda paristo ainoastaan laitevalmistajan suosittelemaan tyyppiin. Hävitä käytetty paristo valmistajan ohjeiden mukaisesti.

WARNING! Explosionsfar ved feilagtig batteri byte. Anvånd samma batterityp eller en ekvivalent typ som rekommenderas av apparatillverkaren. Kassera anvåndt batteri enligt fabrikantens instruktion.

TABLE OF CONTENTS

AC Power & Safety Warnings	inside cover
Program List	2
Introduction	5
Setup	6
Front Panel	6
Back Panel	7
Audio Connection Examples	9
MIDI Connection Examples	10
Performance	11
Setting Levels, Generating a Good Signal	11
Loading Programs from the Front Panel, The LCD Display Window	12
The Harmony Controls, Understanding the Five Harmony Types:	13
Chordal, Scalic	14
Vocoder	15
Chromatic, Pitch Correct, Changing Harmonies with the Softkeys	16
Editing	17
Using Styles, the Menu System	17
Gender	19
Detune	20
Vibrato	21
Scoop	22
Timing	23
Mix	24
Harmony Editing, Changing Softkey Assignments	26
Editing Individual Harmony Styles	27
Customizing A Harmony	29
Naming Programs and Styles, Storing Your Edits	31
Utilities	33
MIDI	33
MIDI Selection of Key and Harmony	35
MIDI Keyboard Split Point, MIDI Song Utilities	39
MIDI Program Dump Utilities	42
I/O Utilities, Initialization Utilities	45
Footswitch Utilities	47
User Utilities, Synthesizer Mode	48
Audio Utilities	49
Song Mode	52
Playing, Creating, Editing, Naming, Arranging Songs	52
Basic Harmony Concepts	58
Appendix 1	Specifications
Appendix 2 - MIDI	MIDI Implementation chart
		MIDI Messages
		MIDI SysEx Dump Formats
		MIDI SysEx Parameters
		Decimal / Binary / Hex equivalents

Studio Vocalist EX Program List

#	Program Name	Program Type	Hints
1	SILKY THICKENER	Auto Doubling	Sing or play a vocal track. No front panel or MIDI input required
2	STEREO DOUBLER		Doubled voice left, input voice right
3	MONO DOUBLER		One double voice plus input voice panned center
4	GROUP DOUBLER		Loose, four voice doubling effect
5	VOICE THICKENER		A small amount of deep Gender without any pitch shift
6	JUST THE GALS		Octave down doubling with male Gender
7	JUST THE GUYS		Octave up doubling with female Gender
8	GUYS AND GALS		Upper and lower octave doubling - 100% wet
9	MALE TO FEMALE	Special Effects	Male Gender and a bit of downward pitch shift.
10	FEMALE TO MALE		Female Gender and a bit of upward pitch shift
11	BLOW ME DOWN		Make sure to eat your spinach!
12	CHER A LIKE		Think Belinda or Buffy
13	CYBERIAN ONE		Robot-like effect. Press a note on the keyboard to change notes
14	CYBERIAN TWO		Robot-like effect. Press a note on the keyboard to change notes
15	CYBERIAN THREE		Press a note on the keyboard to activate the effect
16	I CAN'T SING!!!		Slow, wide vibrato. Betcha can't sing in tune!
17	ETHYL MERMAN		Octave up with wide fast vibrato
18	BARRY TONE		Oooohhhhh Baaaaabbbbyy. Octave down and male Gender
19	HEARTBREAK HOTEL		Shows the maximum voice delay
20	UNDER THE BED	Silly monsters	
21	OAKRIDGE	Chordal Harmony	Play chords on a MIDI keyboard or the front panel while you sing. The harmony voice pitches will follow your voice.
22	STEVE 'N' EDIE		
23	HEAVENLY		
24	ONE UP ON YA		
25	MIDGRADE		
26	TAKE SIX		
27	BARBER POLE		
28	FILL ' ER UP		
29	DEEP CHOIR		
30	DOUBLE UP		
31	KEYBOARD:NOTES	Vocoder	Play individual notes or chords on a MIDI keyboard while you sing. The harmony voices will not automatically follow your voice.
32	KEYBOARD:FEMALE		
33	KEYBOARD:MALE		
34	KEYBOARD:ALVIN!		
35	KEYBOARD:SCOOPS		
36	KEYBOARD:LAYER		
37	KEYBOARD:STEREO		
38	KEYBOARD:PLAIN		
39	KEYBOARD:4CHANS		
40	KEYBOARD:TRANSP		
41	EVERLYS	Scalic Harmony	Select the key and scale of your song from the front panel. Once you have set the key and scale there is no more button pushing required beyond activating Bypass. The different Major and Minor scales offer slightly modified scales to accomodate different input melodies and accompaniment.
42	EAGLES		
43	MANHATTAN		
44	DOOBIES		
45	THIRDS BELOW		
46	NASHVILLE		
47	CLUSTER SIX		
48	DEEP SIX		
49	SUITE JUDY		
50	HUGE 4 PART		

#	Program Name	Program Type	Hints
51	PCorr 1 Hit a note	Pitch Correction	Hit a note from the front panel or a MIDI keyboard while singing.
52	PCorr 2 Major scale		Select the key from the front panel keyboard
53	PCorr 3 Minor scale		“ “
54	PCorr 4 Nearest semi		Sing - all notes will be corrected
55	PCorr 5 1 semi bend		Use the pitch wheel on a MIDI keyboard
56	PCorr 6 2 semi bend		“ “
57	PCorr 7 Instant porta		Hit a note from the front panel or a MIDI keyboard while singing.
58	PCorr 8 Fast porta		“ “
59	PCorr 9 Med porta		“ “
60	PCorr 10 Slow porta		“ “
61	1UP + 2DN	Chordal Harmony	These are extra Chordal harmonies for further experimentation. They work in the same way as programs 21 through 30.
62	1UP + 2DN GEND		
63	1UP + 2DN + BASS		
64	1UP + 2DN + B / GEND		
65	1UP + 3DN		
66	1UP + 3DN / GEND		
67	2UP + 1DN		
68	2UP + 1DN / GEND		
69	2UP + 1DN + BASS		
70	2UP + 1DN + B / GEND		
71	3UP + 1DN		
72	3UP + 1DN / GEND		
73	4UP		
74	4UP 2FH, GENDER		
75	2 OPEN		
76	2 OPEN / GEND		
77	2 OPEN + BASS		
78	2 OPEN + B / GEND		
79	2DN		
80	2DN + BASS		
81	3RD UP CORR	Scalic Harmony	These eight Scalic harmony programs offer pitch-corrected harmonies. They work the same way as programs 41 through 50. Programs with “DBL” in the title mean that your input voice is doubled.
82	3RDS UP CORR		
83	3RD UP + DBL		
84	3RDS UP + DBL		
85	3RD DN CORR		
86	3RDS DN CORR		
87	3RD DN + DBL		
88	3RDS DN + DBL		
89	1 - 3 - 5		
90	1 - 3 - 5 GENDER		
91	5 - 1 - 3		These ten Scalic harmony programs offer some more interesting arrangements and the choice between harmonies that are pitch-corrected or not. You can use the softkeys below the LCD to choose Major or Minor key. The abbreviations “st” and “sm” at the end of the second display line mean “stepped” (pitch-corrected) and “smooth” (not pitch-corrected).
92	5 - 1 - 3 GENDER		
93	3 - 5 - 1		
94	3 - 5 - 1 GENDER		
95	1 - 3 - 5 - 7		
96	1 - 3 - 5 - 7 GENDR		
97	6 - 1 - 3		
98	6 - 1 - 3 GENDER		
99	BYPASS PROGRAM	You can use this program optionally if: A) Your mic is connected to the Studio Vocalist EX B) You're using a 100% wet program for example: BARRY TONE	

INTRODUCTION

Congratulations and thank you for purchasing the DigiTech Studio Vocalist EX. This product is the flagship of the DigiTech Vocalist line of products. It offers a clean and quiet audio path, excellent real time harmony voice generation and sturdy hardware design to provide years of trouble-free service.

Digitech Vocalist products have been used worldwide by virtually every segment of the audio recording and live performance areas. Vocalists are used in the CD recordings you buy, the films and videos you watch and the live concerts you attend.

The new programs in your Studio Vocalist EX are organized in useful groups and cover such uses as automatic doubling, special effects and various harmony generation modes. You can enlist varying degrees of musical intelligence to help you arrange harmony parts quickly and easily; from fully manual, where you pick each harmony note, to semi-manual where you play the chords of your song on a MIDI keyboard and the harmony follows automatically, to fully automatic where you enter the key and scale once and the rest is done for you.

We hope that you enjoy the many useful sounds the Studio Vocalist EX can produce.

The Studio Vocalist EX features include:

- ◆ "Four Voices Plus You" vocal harmony
- ◆ Assignable gender settings to add male or female characteristics
- ◆ Humanization features to further increase realism
- ◆ Front and back panel XLR microphone input
- ◆ Convenient front panel keyboard for quick musical input
- ◆ Selectable Quad (one-voice-per-output) or stereo output modes
- ◆ Footswitch-controlled performance capability (Song Mode)
- ◆ Complete MIDI system exclusive control

SETUP

Front Panel

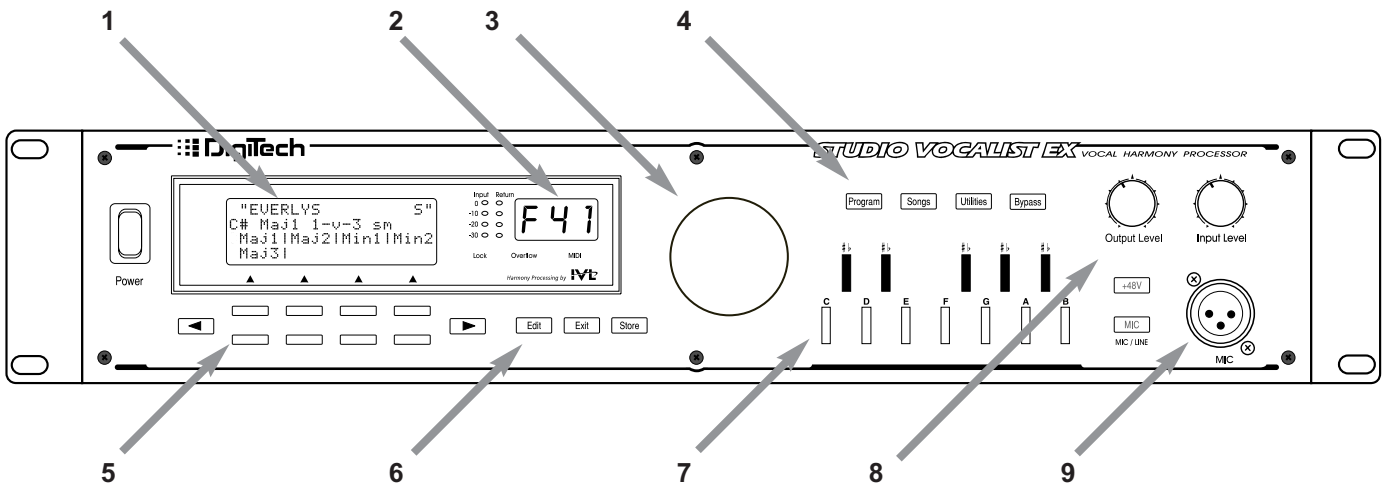

1) LCD display

Provides visual feedback of all operating modes including performance, editing and utility modes.

2) LED displays

The **Input** LED monitors the incoming signal from the Mic and Line inputs. The 0dB LED lights 3 dB before the onset of clipping.

The **MIDI** LED indicates that the Studio Vocalist EX is receiving MIDI.

The **Overflow** LED indicates an overload of the digital signal processor. If it lights, reduce the input gain or front panel mixer faders.

The **Lock** LED shows that the pitch detection circuitry has recognized the input pitch.

3) Data Wheel

In Factory, User and Song modes, the Data Wheel selects and loads programs. In Edit mode, it increases or decreases the value of the selected parameter.

4) Mode button group

The **Program** button selects the program banks for performance or editing.

Song mode is for editing and performance of “songs” which are sequences of chord changes, key types and variations triggered by MIDI, the front panel, or a footswitch.

Utility mode allows access to system, MIDI, footswitch and user preference configurations.

The **Bypass** button mutes the Harmony components from the mix, leaving the Lead Vocal and Reverb. *Note that if the Lead level in a particular program is set to zero, Bypass will mute all sound.*

5) The Softkeys

These keys perform different functions in each different mode; They select harmony variations in the Programs mode and configuration parameters in the Program or Song Edit and Utilities modes. For further information on how these relate to different Programs, see pages 13, 16 & 18.

The Left and the Right Arrow button become active when the ← and → characters are seen in the top corners of the LCD within Edit or Utility mode. Pressing either of the page buttons will present the next or previous editing screen.

6) Edit mode group

The **Edit** button presents the parameter editing screens from within Factory, User and Song modes.

The **Exit** button backtracks through successive menu layers in all editing and programming modes.

The **Store** button offers the option of saving an edited program in the User bank. For more information on editing Programs, see the Editing chapter.

7) Keyboard

This one-octave **keyboard** allows you to input musical information such as Key and Chord root note. The keyboard can also be used to select a cue-in note, which is selectable from the Utilities menu.

8) Level control section

The **Input** control varies the input level for the microphone and line inputs. The raised bump in the control corresponds to 0 dB.

The **Output** control varies the output level for both left and right outputs and the Headphone jack. The raised bump in the control corresponds to 0 dB at +4 dBu nominal, the professional standard for signal levels. If your mixer accepts semi-pro signal levels (-10 dBu) you should reduce this fader.

9) Microphone Input

The XLR-type input jack offers convenient access to the **Microphone Input**. The front and back mic inputs are summed but the Studio Vocalist EX can only accept one audio signal at a time. The **Mic/Line** button toggles between the mic and line inputs, and it will light showing the mic input is enabled. The **+48v** button turns the 48 volt phantom power to both the front and rear panel Mic input on and off.

Back Panel

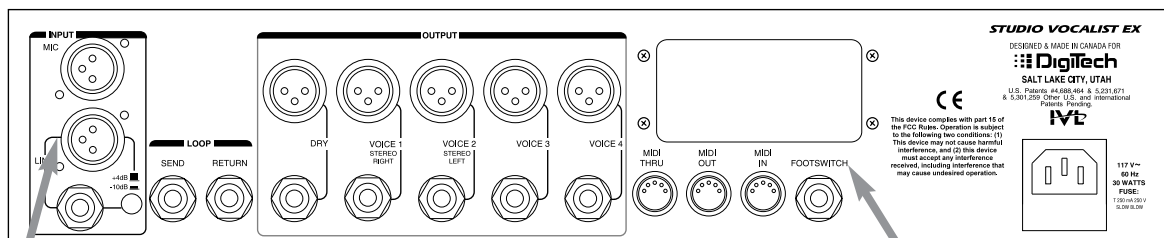

1) Mic input

Balanced XLR jack for microphone-level signals. A cardoid, 1 kOhm-impedance type microphone is preferred.

2) Line inputs

These jacks accept mono line level audio from an external source. Both the 1/4" TRS (tip ring sleeve) and XLR jacks accept balanced or unbalanced signals.

The +4/-10 switch matches the Studio Vocalist EX's line input level to the output level of your mixer. Consult your mixer manual to determine it's output level. This is important to match correctly as excess noise or distortion can result.

- 3) Effects Send and Return** These jacks allow an external processor such as a compressor, equalizer, exciter or de-esser to be inserted in the signal path between the mic preamp and the harmony circuitry. The Send is “normalled” meaning that if a jack is inserted, the signal path from the mic preamp is broken and must be returned through some device.
- 4) “Dry” audio output** This is the direct, unprocessed vocal signal after it has been amplified by the Mic preamp. No harmonies are produced from this output. When an external processor is inserted into the Send and Return loop, its output is produced here.
- 5) Main voice outputs** There are two configurations for these outputs:
- Stereo mode** - Outputs 1 and 2 contain a mix of the the input and harmony voices. Outputs 3 and 4 are muted.
- Quad mode** - Each harmony voice is allocated its own output to allow individual external processing. The input voice is not mixed into any of these outputs.
- 6) MIDI section** The MIDI input receives MIDI control and program information from external MIDI devices such as keyboards and sequencers.
- The MIDI output transmits system, specific button pushes and program information which can be recorded and played back externally from a sequencer. It also can transmit bulk system exclusive data to allow back-up of user data on a MIDI sequencer or voice librarian.
- The MIDI Thru jack transmits an exact copy of any MIDI information received at the MIDI input.
- 7) Footswitch jack** 1/4" stereo jack for a DigiTech FS-300 footswitch to provide remote control of Bypass, Program and Song functions.
- 8) Expansion port** This removeable plate is to accomodate extra hardware for the optional digital I/O card.
- 9) AC Power Jack and fuse** This is a standard IEC receptacle for AC Mains power. The fuse is contained below the receptacle. It may be replaced only with a 250 mA, 250V Slow Blow fuse.

Audio Connection Examples

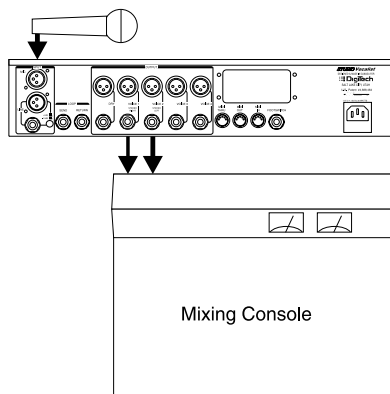

Basic Audio Setup

The drawing at left represents the simplest audio setup. You would most likely use this in live performance or if you are recording with a mixer that has a limited number of inputs.

Connect as follows:

- Connect the microphone to either the front or back Mic input. Press the "Mic" button on the front panel to enable.
- Connect audio outputs 1 and 2 to the inputs of your mixer. Ensure that the audio output mode is set to stereo. This is set in the Utilities menu under the Audio softkey. See page 49 of the Utilities section for further details.

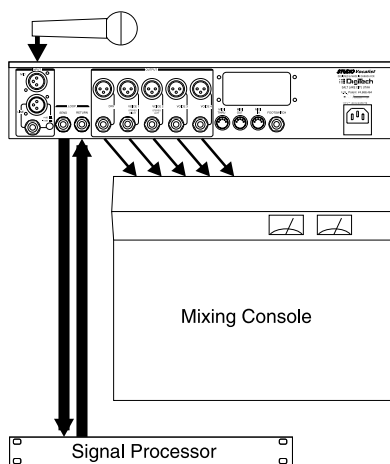

Advanced Audio Setup #1

This setup offers expanded control of the harmony voices and allows external processing of the input voice. The signal processor connected to the loop send and return could perform compression, de-essing, or equalization for example. The individual harmony and dry voice outputs provide the ability to adjust pan, level, equalization and processing separately at the mixing console.

Connect as follows:

- Connect the microphone to either the front or back Mic input. Press the "Mic" button on the front panel to enable.
- Connect audio outputs from the dry voice and the four harmony voices to the inputs of your mixer. Ensure that the audio output mode is set to Quad. This is set in the Utilities menu under the Audio softkey. See page 45 in the Utilities section for further details.
- Connect the Loop Send of the Studio Vocalist EX to the input of the effect processor and the Loop Return to the output of the effect processor.

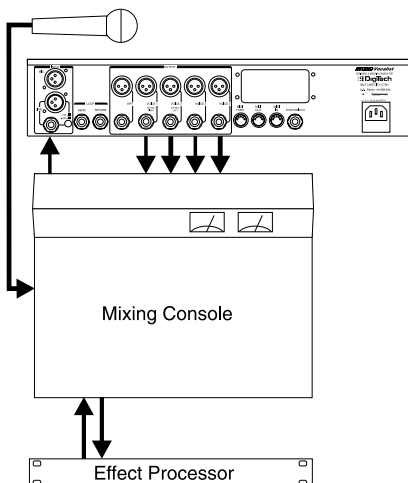

Advanced Audio Setup #2

This is the most likely studio arrangement. It allows you to use the microphone preamp in your console and provides the most flexible arrangement for pre and post effects generation. There is no dry voice output because that is connected directly through the board and monitoring and routing can be done there. The individual harmony outputs allow you to adjust pan, level, equalization and processing separately for each voice.

Connect as follows:

- Connect the microphone to your mixing console input.
- Connect the output from your console auxiliary send to the line input on the Studio Vocalist EX.
- Connect the four harmony voice outputs to inputs on your mixer. Confirm that the output mode is set to Quad. See page 45 in the Utilities section for further details.
- Connect the required dynamic (compression, limiting) or spatial (reverb, delay) effects processors to your mixing console auxiliary send and return loops.

MIDI Connection Examples

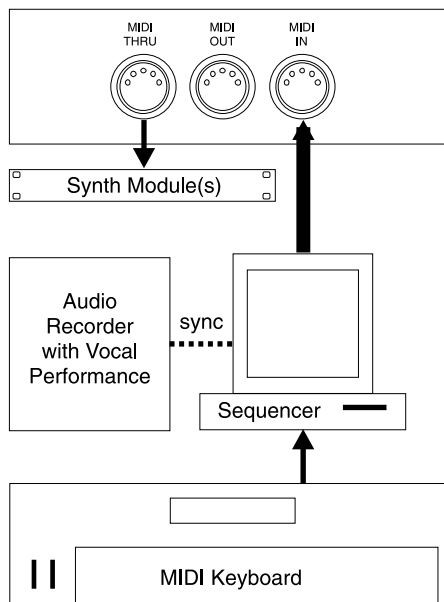
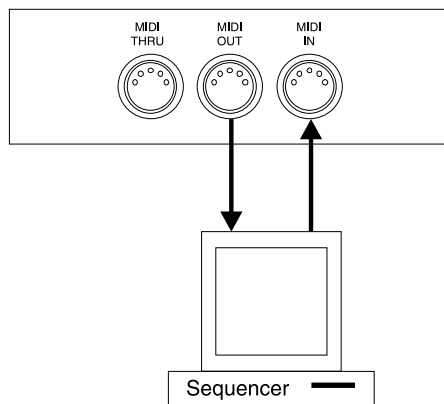
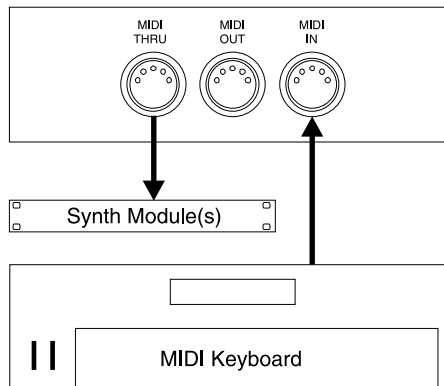

Basic MIDI Setup

This setup could be used for a live performance or live recording situation. The Studio Vocalist EX can recognize the chords you play and output the appropriate harmony or you could use a Vocoder preset to play the exact harmony notes you need. These concepts are explained in greater detail later on in this manual.

Connect as follows:

- Connect the output of your controller keyboard to the MIDI in of the Studio Vocalist EX.
- Set your keyboard's MIDI transmit channel to 1 (the Studio Vocalist EX's default channel) or change the Studio Vocalist EX's MIDI receive channel to match your keyboard. See page 33 in the Utilities section for further details.
- Connect any MIDI sound modules to the MIDI thru jack.

Intermediate MIDI Setup

This configuration allows you to record key, chord and harmony style change keystrokes from the front panel into a sequencer for automated playback later. This could be useful for live vocal performances using sequenced backing tracks. You could also use the sequencer to back up your edited patches to disk. If you do extensive editing, it is very important to store backup copies of your work.

Connect as follows:

- Connect the MIDI output of the Studio Vocalist EX to the input of your sequencer or storage device.
- Connect the output of the sequencer or storage device to the Studio Vocalist EX's input.
- The patch dump from the Studio Vocalist EX to the storage device must be initiated from the Studio Vocalist EX. The Studio Vocalist EX can receive a patch dump at any time. See page 42 in the Utilities section for further details.

Advanced MIDI Setup

The setup at left may be found in many audio and MIDI recording studios. The sequencer allows you to record and edit the keyboard performance that controls the harmony voices. Routing the vocal performance through the Studio Vocalist EX and controlling it with the sequencer allows you to “craft” exactly the harmony performance you want. *Connect as follows:*

- Connect the MIDI output of your keyboard to the input of the sequencer.
- Connect the MIDI output of the sequencer to the input of the Studio Vocalist EX.
- Connect your MIDI sound module(s) to the Studio Vocalist EX's Thru jack.

PERFORMANCE

This chapter discusses the main operating features of the Studio Vocalist EX. It begins with setting the correct levels and proceeds with discussions of the different harmony modes and their uses.

We assume that you have connected your Studio Vocalist EX according to the diagrams on the previous pages and that you are familiar with the other devices in your system.

Setting the Input and Output Levels

First, move the input and output level controls down to the bottom position.

Input Level

Sing into the microphone and turn up the Input Level control until the loudest passage you sing causes only brief peaks to register on the red 0dB LED. Too much input gain causes both the unprocessed (dry) vocal signal and the harmony voices to distort. Too little gain and the Studio Vocalist EX will not produce harmonies at all.

Output Level

Once you have set the input level, sing into your mic and bring the Output level fader up to the nominal level “bump” at halfway up the fader’s travel. This will set the output level to nominal +4 dB. If you are sending audio to a mixer input that operates at -10 dB, reduce this control according to the mixer’s input meters.

Generating a Good Signal

It is important that the singer perform as close as possible to the microphone in order to reduce unwanted harmonization of background noise. In a quiet studio environment this is less critical but on a loud stage, the singer’s voice must be considerably louder at the microphone than any other sounds.

It is also important to avoid using omnidirectional mics. They can pick up reflections and noise that disrupt the Studio Vocalist EX’s pitch detection. Use directional microphones only; these microphone’s pickup patterns are generally called “cardoid” or “hyper-cardoid”.

The Signal Lock LED turns on when the Studio Vocalist EX recognizes the pitch of the input signal. If this LED turns on weakly or flashes during sustained vocal notes, the input level must be increased either by singing louder or adjusting the Input Level control.

Loading Programs

The Studio Vocalist EX is shipped from the factory with the first factory program selected once it is powered up. Turn the Data Wheel knob to scroll through the different factory programs. Programs are loaded automatically as you turn the wheel. Programs can also be loaded via MIDI program change.

There are two banks of programs to choose from with 50 programs in each. The “Factory” or “User” button will light up when either of these banks are chosen. You can save edited programs into the User bank only. See “Storing your Edits” for further details.

The LCD Display Window

When you load a new program, the LCD displays information you will need in order to control the harmony voices. The following graphic shows these details:

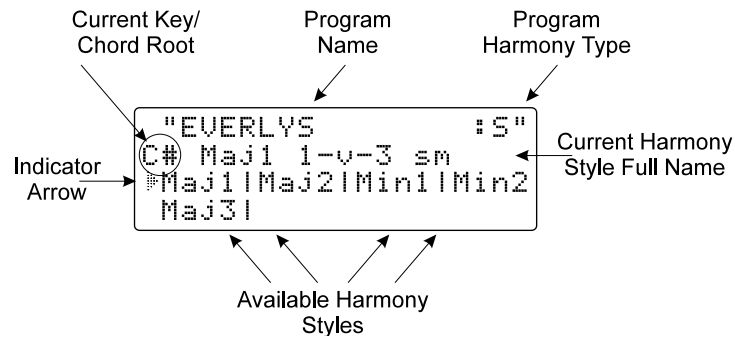

Current Key/Chord Root

This two character field shows the current key or chord root note in Scalic or Chordal harmony programs only.

Program Name

A name of up to 16 characters is shown here. There may be identical names in the User bank if edits have been made.

Program Harmony Type

In Scalic or Chordal harmony programs only, this character will be either an “:S” or a“:C”. The “S” shows that the program is based on a Scalic harmony, while the “C” shows that the program is built on a Chordal harmony.

Indicator Arrow

This shows which of the available Harmony Styles is currently loaded. It will move when you press the Softkeys to select another Harmony Style.

Available Harmony Styles

Each Program may have up to 8 different Harmony Style variations. These variations are based on the Harmony Type featured in the current program. Each “window” shows the first four characters of the style name. For more information see the section called “Understanding the Five Harmony Types”.

Current Harmony Style Full Name

This 16 character field shows the full name of the current Harmony Style.

The style naming conventions are described in the “Understanding the Five Harmony Types” section.

The Harmony Controls

For musically correct harmonies to be generated automatically, you must provide the Studio Vocalist EX with some musical information. It’s just like when you are playing with other musicians; they need to know what chords you’re playing in order to stay “in key” with you. You can use either a MIDI keyboard or the one-octave keyboard and eight softkeys to provide this information.

Note: The first harmony style (top left softkey) is always loaded when a new program is loaded.

When you load a Program based on Chordal or Scalic harmony, the eight **softkeys** may be used to call up a different harmony variations. Each Softkey corresponds to a harmony style on the LCD display (see example below).

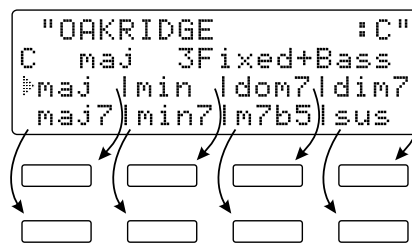

Several different harmony styles are assigned to each program so that you don’t have to load a completely different program when, for example, you want to change from a major to a minor harmony.

Different Programs require different control input from you. For example, you can use the front panel keyboard (or MIDI keyboard notes) to choose the *root note* of the chord in a Chordal Program, the *Key* in a Scalic Program, or the actual harmony notes to be played in a Vocoder Program.

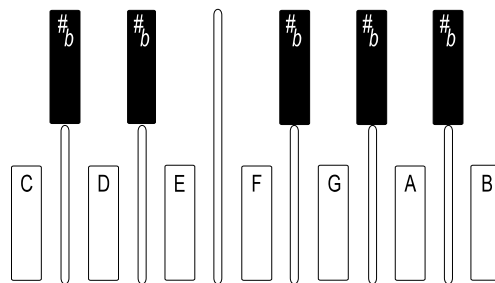

Understanding the Five Harmony Types

Each program is based on one of five basic harmony types. The differences lie in the control method you choose and the sound you are after.

The Studio Vocalist EX’s five basic harmony types are:

- **Chordal** These three Harmony types need musical control from you as you are singing.
- **Scalic**
- **Vocoder**

- **Chromatic** These two Harmony types are for more specific uses. Chromatic doesn't require any special musical control. Used in **Unison** presets to thicken the sound of the Lead vocal.
- **Pitch Correct** Pitch Correct can take input from a pitch bend wheel, front panel keyboard or a MIDI note.

Chordal

You can tell a program is based on Chordal harmony when the upper right hand character of the display shows “:C”. You will also see first letter of the harmony style name shown in lower case letters (e.g. maj, min, maj7). To use a Chordal harmony program, you must input each chord in your song as it occurs. Chord input can come from chords you play on a MIDI keyboard or from the front panel harmony controls. The Studio Vocalist EX has intelligent MIDI chord recognition to interpret the chord inversions you play to produce correct harmonies.

A chord has two parts: the *root note* and the *type*. An example of this would be an A major 7th chord which has “A” as its root and “major 7th” as its type.

Uses: provides a constant chordal harmony “bed” that stays on the currently selected chord. Chordal harmonies automatically move harmony intervals so that they sound correct over your lead voice melody.

For examples of Chordal harmony, choose any of the Programs 21 through 30. Choose a root note on the front panel keyboard and sing. As you sing, use the softkeys to switch between major, minor and the other chord types, and listen to how the harmony voices change.

Style naming conventions: The first 3 to 4 characters of the name show the chord type such as maj, min, dom7 etc. The 2 to 7 characters following the chord type show the arrangement of the harmony voices above and below your voice. The number with an arrow beside it shows how many scale intervals away from the input note the harmony will be and whether it is above or below. The B character shows that a bass voice is present that will move less than the other voices. *Fixed* means that the harmony voices will move less too.

Scalic

You can tell a program is based on Scalic harmonies when the upper right hand character of the display shows “:S”. The first letter of the harmony style name is capitalized (e.g. Maj1 and Min1). Scalic harmony programs require that you to enter the *key* and *scale* which usually needs to be done only once at the beginning of your song. In western popular music, the chords often revolve around a single scale such as A major where “A” is the key and “major” is the scale around which all the chords of the song are centered.

Note: Scalic harmony programs that generate a single 3rd interval generally work for more songs than programs with a combined 3rd and 5th.

Programs based on Scalic harmony have a selection of different scales you can choose from by pressing the softkeys. For example, the “Everlys” program (#41) has 3 different major scales and two minors as do many of the other Scalic-based programs. The major scales differ only on the harmony note generated on the fifth note of the scale i.e. Maj1 generates a major chord, Maj2 generates a suspended chord and the Maj3 generates a minor chord. The two minor scales differ in that they generate a major chord on the *fourth* note (Min1) or a minor chord (Min2). This may seem a bit confusing so rely on your ears to make the appropriate choices.

Use: Scalic harmonies are more active in harmony motion where Chordal tends to be less so. Scalic programs sound the most natural for popular song harmony.

For examples of Scalic harmony, choose any of Programs 41 through 50, choose the key on the front panel keyboard and sing. Notice that as you sing up and down the melody, the Harmony voices stay very close to you.

Style naming conventions: The first 3 to 4 characters of the name show the scale type such as Major, Minor, Dorian etc. The next 3 to 5 characters show the voicing. For example: “v3355” as found in the Eagles program shows that your lead voice (v) has doubled 3rd and doubled 5th harmonies above it. Numbers to the right show harmonies above and numbers to the left show harmony voices below.

You may also see two additional characters “sm” and “st”. This displays the setting of the Bending parameter, which determines whether the harmony voices will follow the lead vocal sliding smoothly between notes (sm) or whether the harmony will not slide between notes but will jump from scale note to scale note in a stepped fashion (st).

For more information on Chordal and Scalic harmony, see the Basic Harmony Concepts chapter.

Vocoder

Vocoder mode is named after a completely different technology that functions in a similar way. It is not the familiar “robot voice” sound. The Studio Vocalist EX’s Vocoder mode does not feature intelligent harmony because you play the notes from a MIDI keyboard or the front panel keyboard that you want to hear as harmonies. Vocoder mode is probably the most flexible mode allowing you to weave intricate melody lines from your MIDI keyboard that can be recorded and edited in a MIDI sequencer like any other MIDI performance.

Use: Vocoder is for situations where neither a straight chord nor a parallel harmony line will do. Since you directly control the notes being “sung”, you can create counter-melodies and harmonies that go in different directions. While it is more efficient to use a MIDI keyboard in Vocoder programs, the front panel keyboard is active in these programs as well.

For examples of Vocoder harmony, try Programs 31 through 40. Hold down any chord up to four notes on the front panel keyboard or a MIDI keyboard and sing. Keep in mind that no sound will come out unless you are holding down some keys. Change the chord, and the Harmony voices change. You don't even have to sing—talk into the mic as you play different notes on the keyboard.

Chromatic

Chromatic mode does not require the Studio Vocalist EX's intelligent harmony because the harmony notes always remain a fixed interval away from the input note. This harmony type is used in programs that feature unison, octave, or fifth interval harmonies. You do not need to enter key information when you load Chromatic harmony programs.

Use: Chromatic Harmony is good for fattening up a vocal (live or recorded, solo or group) by doubling the Lead with unison Harmonies, and octave up or down harmonies.

For examples of Chromatic harmony, choose any of Programs 1 through 8.

Pitch Correct

Pitch Correct mode is not intended for harmony. It offers you a method of manipulating a singer's pitch when needed. The Studio Vocalist EX has ten programs dedicated to Pitch Correction.

Use: Pitch Correct is used to force an out-of-tune vocal performance into the correct pitch. Use it to "rescue" a recorded track where the performance is good but some of the notes are out of tune.

For examples of Pitch Correct, choose Programs 51 through 60. The program list at the beginning of this manual provides more tips on setup.

Changing Harmonies with the Softkeys

The softkeys below the LCD are offered in factory programs that are based on Scalic and Chordal harmony. All other factory programs feature one softkey selection only. The top left softkey assignment is automatically loaded when you change programs.

In the Scalic harmony programs (#36 to 45) the softkeys allow you to select different Major or Minor scales to provide the correct harmony for your song. These scales have subtle differences that make a harmony sound acceptable or not. Once you have entered the key of your song with the front panel keyboard, you can try each scale to determine which is correct.

In the Chordal harmony programs (#16 to 25) the softkeys allow you to select chord types. While this more easily done with a MIDI keyboard, the softkeys allow easy access if no keyboard is available.

See "Harmony Editing" on page 26 for changing softkey assignments and creating new harmony styles.

EDITING

This chapter describes the general principles of editing in the Studio Vocalist EX and the individual editing modes in detail. To reduce the amount of redundant information, the general procedures, menu system and controls are described at the beginning of the chapter followed by detailed discussions of each of the edit parameters.

The Harmony editing screens are split up in successive layers of complexity. This is done to make this section easier to understand.

Using Styles to Simplify Editing

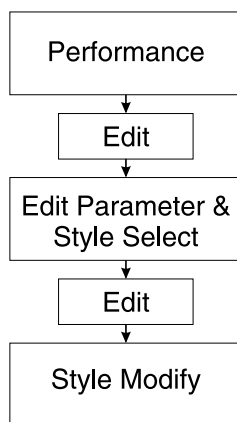

When you press the **Edit** button in Programs mode, you enter into an area that can be as simple or as flexible as you want. Modifying a program can be as easy as choosing a preprogrammed style or as involved as going into the deepest layer and adjusting a single parameter.

To simplify the editing process, we have reduced the number of individual parameter changes you need to make by introducing what we call “styles”. Styles simplify editing by collecting related parameters together in a group and giving them a name. For example, this is done so that it is not always necessary to change the vibrato depths on each of the four voices to add a little more vibrato overall.

The “humanizing” features: Gender, Detune, Vibrato and Scoop each have their own library of styles from which you can choose. Harmony uses a variation on the style concept which is described later in this chapter. The Mix and Program Name parameters do not use styles.

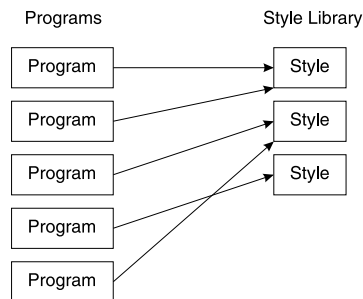

Editing a program in the Studio Vocalist EX can be done in either of two ways: you can change which style is assigned to the program or you can create a new style to assign to the program. In both cases you will be using the concept of a “library” all of the programs share from. If you do build up your own library of user styles, keep in mind that if you edit a user style that is shared by other programs these programs will be affected in the same way.

The factory styles have been constructed to give you a broad range of choices from which you can personalize your programs. You cannot permanently modify a factory style but you can make changes and save them to a new user style.

The Menu System and Editing Controls

The Studio Vocalist EX menu system is designed to allow easy access to all editable parameters in it. It is composed of several layers; each layer has decision branches leading to subsequent layers. We have deliberately limited the number of layers to encourage you to experiment without making you learn a complex menu system.

The controls used to navigate the menu system are shown in the graphic following:

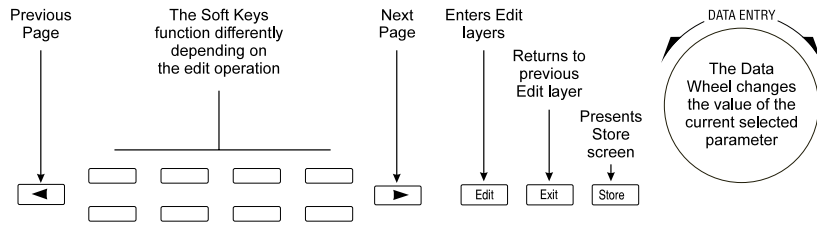

The Edit Button

When pressed from Factory or User Programs mode, the **Edit button** presents the Parameter/Style Select screen. Once a parameter is selected, another press of the **Edit button** enters the Style Modify screens.

When pressed from Songs mode, the **Edit button** presents the Arrangement screen. An additional press of the **Edit button** presents the Section editing screen. See page 54 in the Songs mode section for further details.

The **Edit button** will light indicating you have entered Program Edit or Song Edit modes and it will stay lit as long as you are there.

The Soft Keys

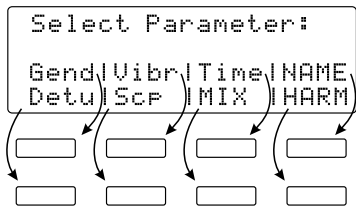

In all modes, each layer of the menu system contains a different group of softkey assignments. They perform the following functions:

- to select the parameter you want to modify,
- to select the harmony voice you want to make a change to,
- increment or decrement the value of the selected parameter by one.

The Data Wheel

The Data Wheel changes the parameter you have selected. It is a detented (clicking) rotary encoder type with no start or stop point.

- At the top level of Factory or User modes, it is used to load programs.
- At the top level of Songs mode, it is used to load songs.
- In all Edit modes, it is used to increment or decrement the value of the selected parameter.

The Data Wheel has a speed-sensitive feature that can access a large number of individual steps without turning the wheel excessively.

The Left and Right Arrow Buttons

These buttons are active only when you see the ← and → characters displayed in the upper corners of the LCD. They allow you to access the various editing screens in Factory, User, Songs and Utilities modes.

Pressing the arrow buttons presents the next or previous edit screen. Repeated presses loop around the available screens.

The Store Button

The **Store** button allows you to save any changes you have made to a program or style. You can also use it to copy programs and styles to other locations. Store can be pressed in any Studio Vocalist EX mode except for Utilities. Refer to the section on “Storing Your Edits” at the end of this chapter to save your changes.

The Exit Button

This button presents the previous menu layer screen. Pressing it repeatedly will backtrack through the menu layers to the last used mode.

Gender

The Gender styles introduce a unique harmonic character into the harmonies to add the qualities associated with male or female voices. This makes the harmonies sound more as if they are coming from a distinctly separate group of people rather than being multiples of you. The two editable parameters for Gender are Assignment and Setting.

Assignment

There are two Genders assignable for each program. You can assign a male Gender to a lower harmony and a female Gender to a higher harmony for instance. This can also be reversed for special effects.

To assign no Gender to voices, you must still assign Gender 1 or 2 to those voices and change the Gender setting to 0.

Note: Each voice must have a Gender setting even if it is zero

Setting

The Gender settings range from +50 to -50. The positive values shift the overtones higher for female characteristics and the negative values shift the overtones lower for male characteristics.

To assign no Gender to voices, you must still assign Gender 1 or 2 to those voices and change the Gender setting to 0.

To edit the Gender parameters:

1. Use the Data Wheel to select the program you want to edit and press the **Edit button**.
2. Press the softkey that corresponds to Gender. (**Gend**)
3. Select a different style preset using the Data Wheel. If you are satisfied with loading a different style, refer to the “Storing your Edits” section. Press the **Edit button** again to modify the current Gender style or, to create a new Gender style from scratch, load one of the blank styles (**BlkGend #**) and then press the **Edit button**.
4. Press the softkeys below the LCD to select which voice you want to modify.
5. Turn the Data Wheel to change the Gender assignment for the selected voice. The softkeys can also be used for this purpose.

6. Press the Right Arrow button to go to the Gender settings screen. You will see the settings for Gender #1 on the left and #2 on the right.
7. Select which Gender setting you want to change with the softkeys and turn the Data Wheel to make the changes.

Detune

The Detune styles add a subtle “out-of-tuneness” to the harmony voices. Because human voices are never perfectly in tune, this function can “humanize” your harmonies. This feature also works well on programs where two, three or all four voices are singing the same note (unison), as the detuning produce a chorusing effect.

The editable parameters in a Detune style are: Amount, Randomness and Pitch Randomize. These are set individually for each voice.

Amount

This sets the number of cents sharp or flat the harmony voices are. The amount is editable in 1 cent increments between 100 cents (1 semitone) above or below the input note.

Randomness

This makes every new harmony note have a slightly different detune amount. It is variable from zero to 25 cents in 1 cent increments. Randomness will only reduce the detune amount, not add to it - for example, a Detune amount of +12 cents with Randomness set to 6 cents would vary from +6 to +12 with each new note.

Pitch Randomize

Pitch Randomize further humanizes your harmonies by continuously varying the pitch through the *duration* of a note. You have a selection of low, medium or high settings.

To edit the Detune parameters:

1. Use the Data Wheel to select the program you want to edit and press the **Edit button**.
2. Press the softkey that corresponds to Detune (**Detu**).
3. Select a different style preset using the Data Wheel. If you are satisfied with loading a different style, refer to the “Storing your Edits” section on page 32. Press the **Edit button** again to modify the current Detune style or, to create a new Detune style from scratch, load one of the blank styles (**BlnkDetu #**) and then press the **Edit button**.
4. To modify the amount of Detune effect on the first voice, turn the Data Wheel. Press the softkeys below the other voices to select them for editing. The softkeys can also be used to change values.
5. To edit the Randomness parameter, press the Right Arrow button to move to the next edit screen. Select the voices with the softkeys and increase or decrease the amount of Randomness with the Data Wheel.

6. To edit the amount of Pitch Randomization, press the Right Arrow button. Turn the Data Wheel to adjust to the desired value.

Vibrato

Adding Vibrato to the Studio Vocalist EX's harmonies is another way of adding realism. Vibrato is the regular modulation of a voice's pitch that lends interest to an otherwise static note. You can edit five different vibrato parameters for each voice allowing you to construct the most realistic vibrato performance possible.

Depth

This varies the amount of pitch deviation above and below the root pitch of the harmony note. This varies in 1 cent increments between 0 and 100 cents.

Rate

This is the modulation speed of the vibrato. It is measured in Hertz (Hz: the number of cycles per second). This can be varied in tenths of one Hz between 0 and 9.9 Hz.

Type

This gives you a selection of four different vibrato waveforms. They are: sine wave, square wave, sawtooth up and sawtooth down.

Delay

This changes the time between when the Studio Vocalist EX produces a harmony note and the onset of vibrato. Vibrato does not immediately occur after the delay period; instead it increases gradually in intensity. It is edited in 20 millisecond increments from 0 to 2.5 seconds.

Randomness

Randomness applies random values to the combination of Depth and Rate. Each new note you sing will have a slightly faster or slower vibrato rate and slightly increased or decreased depth. This parameter is set from 1 to 10.

To edit the Vibrato parameters:

1. Use the Data Wheel to select the program you want to edit and press the **Edit button**.
2. Press the softkey that corresponds to Vibrato. (**Vibr**)
3. Select a different style preset using the Data Wheel. If you are satisfied with loading a different style, refer to the "Storing your Edits" section on page 30. Press the **Edit button** again to modify the current Vibrato style or, to create a new Vibrato style from scratch, load one of the blank styles (**BlkVibr #**) and then press the **Edit button**.
4. To increase and decrease the Vibrato Depth on voice number one, turn the Data Wheel. Press the softkeys below the LCD to select

other voices for editing. The softkeys are also be used to raise or lower values.

5. To edit the Vibrato Rate, press the Right Arrow button to move to the next edit screen. Select one of the voices with the softkeys and use the Data Wheel to edit the value.
6. To vary the Vibrato Delay, press the Right Arrow button to move to the next edit screen. Select one of the voices with the softkeys and use the Data Wheel to edit the value.
7. To edit the Randomness parameter, press the Right Arrow button to move to the next edit screen. Select one of the voices with the softkeys and increase or decrease the amount of Randomness with the Data Wheel while you sing.

Scoop

“Scooping” refers to a technique singers use where they bend the pitch into a note from below the target pitch. This feature makes your Studio Vocalist EX harmonies sound like a group of singers improvising their parts.

There are two ways of introducing Scoop: you can use the Randomness factor in the Scalic, Chromatic and Vocoder modes to have the voices scoop automatically at random intervals or, in Vocoder mode only, you can introduce it deliberately via MIDI velocity. Scoop does not function in Pitch Correct mode.

Scoop Occurrence

This parameter allows you to set how often you would like the Studio Vocalist EX to produce a scoop. A 50 percent occurrence rate means that, on average, one in every two notes you sing will scoop into pitch.

Scoop Amount

The amount of Scoop is applied in cents, from 0 to 900. Zero is no scoop and 900 is equivalent to 9 semitones. The higher values are not intended to produce long portamento-type slides into a note; they are intended to sound more like the voice has quickly come up from a non-pitched note below the input note.

Scoop Rate

Scoop time is variable from 0 (slowest) to 10 (fastest). The numbers represent a range of acceptable rates but are not referenced to any specific time scale.

Vocoder Scoop Threshold (Vocoder styles only)

With a Vocoder style currently loaded, this parameter allows you to produce a scooped harmony note only when you hit a keyboard note (or notes) above a certain velocity. The MIDI velocity range can be set from 0 to 127 although you will most likely be using the higher velocities.

To edit the Scoop parameters:

1. Use the Data Wheel to select the program you want to edit and press the **Edit button**.
2. Press the softkey that corresponds to Scoop. (**Scp**)
3. Select a different style preset using the Data Wheel. If you are satisfied with loading a different style, refer to the “Storing your Edits” section on page 30. Press the **Edit button** again to modify the current Scoop style or, to create a new Scoop style from scratch, load one of the blank styles (**BlkScp #**) and then press the **Edit button**.
4. The first screen is the Scoop Occurrence setting. This should be set to the maximum value (100%) while you are experimenting with the other Scoop parameters. When you have set the other parameters to your liking the Occurrence setting can be reduced.
5. To set the Scoop amount press the right arrow button. Turn the Data Wheel to edit voice #1. Select the other voices with the softkeys beneath them and modify them with the Data Wheel.
6. To set the Scoop rate press the right arrow button. Turn the Data Wheel to edit voice #1. Zero is the slowest and 10 is the fastest rate. Select the other voices with the softkeys beneath them and modify them with the Data Wheel. To get your bearings, start by setting the rates at the lower settings and increase once you find the Scoop Amount that you like.
7. (Vocoder styles only) Press the right arrow button to advance to the Vocoder Threshold screen. The Data Wheel changes the value above which scoops are triggered by keyboard velocity.

Timing

This parameter adds a short timing delay between your input note and the onset of the harmony voices. This delay is set individually for each of the four voices to stagger their initial attack. Because singing groups rarely hit the start of their notes at exactly the same time, this adds more human qualities to the harmony effect.

Timing Delay

The timing delay is varied in 5 millisecond steps from 0 to 80 msec. Each voice can have a different delay setting.

Timing Randomness

This parameter varies the amount of delay up to a maximum value that is set as the current Timing Delay. It provides a different delay for each new note you sing. Timing Randomness is set between 1 and 10 with 1 being a small amount of deviation and 10 producing delays between 0 ms and the current Time Delay setting.

Attack and Release (shown in Vocoder styles only)

These parameters soften the onset and decay of the harmony voices during sustained singing input notes. They are only available in Vocoder mode because there are times, such as when no keys are held down,

when no harmony is heard and you might want to soften the jump from silence to the harmony voices.

If you sing a sustained note and then press a key on your keyboard, a slower Attack makes the harmony voices fade in a bit more gradually. The Release parameter adds a slight sustain effect to the harmony voices that is only audible if you release the keyboard note while you are still singing.

The Attack and Release parameters modify all 4 voices simultaneously and are set in 10 ms steps from 0 to 2.5 seconds maximum.

To edit the Timing parameters:

1. Use the Data Wheel to select the program you want to edit and press the **Edit button**.
2. Press the softkey that corresponds to Time.
3. Select a different style preset using the Data Wheel. If you are satisfied with loading a different style, refer to the “Storing your Edits” section on page 30. Press the **Edit button** again to modify the current Timing style or, to create a new Timing style from scratch, load one of the blank styles (**BlkTime #**) and then press the **Edit button**.
4. Turn the Data Wheel to edit the timing of voice #1. The graph and numerical displays increase values. Press a softkey from either row beneath the four voices to select that voice for editing.
5. Press the Right Arrow button to advance to the Timing Randomness screen. Use the softkeys to select voices and the Data Wheel to adjust the values.
6. Press the Right Arrow button to advance to the Attack and Release screen.
7. (Vocoder styles only) Turn the Data Wheel to edit the Attack of all 4 voices. The graph and numerical displays increase values. Press a softkey on the right side of the screen to select the Release parameter and turn the Data Wheel to change its value.

Note: If you are not in Vocoder mode, press the Right Arrow button to advance directly to the Timing Style Name screen instead.

Refer to the section on “Storing Your Edits” on page 31 to save your changes.

Mix

Each program in the Studio Vocalist EX can be stored with unique mixer settings (there are no “Mix” Styles). This allows you to bring up the level of a single harmony voice for example or to turn the lead voice off for a 100% wet special effect. Each program can also have its own pan settings.

Note: If the Lead (dry) Voice is set to 0 in a program, all audio (not just the harmonies) will be muted when the Bypass is activated.

Harmony/Lead Mix

This parameter varies the mix between your unaffected input voice and the sum of the harmony voices. Both settings are interactive, that is, setting either sets both. The relative levels are displayed in percent.

Harmony Voice Levels

The volume of each of the four voices are adjusted independently. The levels are edited in 1 dB increments between 0 dB (full volume) and off.

Harmony Voice Pan

Each harmony voice can have its left/right orientation in the stereo field edited between 50 increments left and 50 right with the center point being 0. A graphical display shows the relative positions.

Input Vocal Pan

The lead voice (also known as “dry”) can be panned to any point in the stereo field in the same way as the harmony voices.

To edit the Mix parameters:

1. Use the Data Wheel to select the program you want to edit and press the **Edit button** then the softkey corresponding to Mix.
2. To adjust the Harmony/Lead mix, turn the Data Wheel. The bar graphs showing the relative levels move together.
3. To adjust the individual harmony levels, press the Right Arrow button. The LCD shows the current attenuation as a vertical bar with a numerical dB level. Remember, 0 dB is full volume for the selected voice. Press the softkeys below the other voices to select them for level adjustment. The softkeys may also be used to raise or lower values.
4. To edit the individual voice pans, press the Right Arrow button. In this screen, the voices are stacked vertically but still correspond to the softkeys in the same way as the other edit screens. When you move the Data Wheel, the pan pointers move diagonally across the screen to give you a visual indication of where the voice is placed in the stereo field. The stereo position is also shown by the letters “L” (left), “R” (right) and “C” (center) with a number from 1 to 50 showing how far the voice is from the center position.
5. To change the panning of the lead voice, press the Right Arrow button to move to the Dry Pan screen. Turn the Data Wheel to change the pan position as described in the individual pans.
6. Press **Store** to save your changes or press the **Exit** button three times to return to the top level.

Harmony Editing

The Studio Vocalist EX has automatic functions capable of producing musically correct harmonies and a large number of factory programs crafted to fit many performance situations. There may be, however, instances where the factory harmonies need to be edited to suit your requirements.

The Studio Vocalist EX allows you to shape the harmonies from the point of replacing one chord type with another in a Chordal harmony program for example, to the point of determining exactly which notes the Studio Vocalist EX generates for any series of input notes in a Scalic harmony program.

Harmony styles work in a slightly different way from the humanizing styles. Where only one Detune or Vibrato style can be assigned to a particular program, there are 8 different harmony styles assignable per program that can be called up using the softkeys.

We will divide the harmony editing section into 3 levels for simplicity:

- Level 1. Changing the Softkey assignments of Harmony Styles
- Level 2. Editing Harmony Styles
- Level 3. Customizing Harmony Styles

Level 1: Changing the Softkey Assignments of Harmony Styles

This is the simplest level in which to modify the harmony component of a program. You have a choice of pre-programmed harmony styles that can be attached to the various programs to suit your needs.

Assignment of Harmony Styles to Softkeys

Each of the eight softkeys can be re-designated to enable a different harmony style when pressed. The same styles can be shuffled or a different style can be chosen for a particular softkey.

An example could be if you have chosen a program that produces a Chordal harmony with the voicing you want but it doesn't have an augmented 7th chord assigned to any of the softkeys, you could change its assignment from something you don't need such as a diminished 7th.

Changing the Style Assigned to a Softkey:

1. Use the Data Wheel to select the program you want to edit and press the **Edit button**.
2. Press the softkey that corresponds to the Harmony parameter. The LCD shows the the current softkey selected by an arrow, its harmony style in quotation marks, and the other softkey assignments.
3. Press the softkey you want to reassign. The style display shows the key's current assignment.
4. Turn the Data Wheel to select a different harmony style. You have a number of different styles to assign to each softkey. See "Style Type, Scale or Chord Select" described below for their descriptions.
5. If you want to reassign another softkey, press it and repeat step #4.

6. When you are satisfied, press **Store** once to save your changes. See “Storing Your Edits” at the end of this chapter for more details on saving.

Level 2: Editing Individual Harmony Styles

If you can't find the harmony style you need from the pre-programmed harmony styles, you can enter the next editing level and create or modify one for yourself.

You have a choice of the following harmony style editing parameters:

Harmony Type, Scale or Chord Select

You can choose between Chromatic, Scalic, Chordal, Vocoder and Pitch Correct harmony types to assign to your harmony style.

For Chordal harmonies, this screen allows you to choose between major, major 7th, minor, minor 7th, dominant 7th, minor 7th flat 5, diminished 7th, augmented 7th, suspended and suspended 7th chord types.

If you choose Scalic harmony, this screen also allows you to choose the scale type which can be Major, Minor, Whole tone, Diminished, Blues, Dorian, Harmonic Minor and Melodic Minor.

The Chromatic, Vocoder and Pitch Correct types do not require any scale or chord selection.

Unison is not a specific Harmony Type, but you will see it in some of the Program titles. It is a Chromatic harmony set to double the lead voice at the same pitch, or very close to it.

Harmony Voicing (Except Pitch Correct and Vocoder)

This parameter allows you to arrange the intervals relative to your input note such as a 3rd above or 5th below harmony. The Harmony Voicing screen is available only to the Chordal, Scalic and Chromatic harmony types only. Each of the three types has a different number of voicing intervals available because of the nature of each type of harmony.

Chordal harmonies allow you to choose intervals that belong to the current chord type only. The range is plus or minus 2 octaves with a separate bass voicing. The Bass voicing stays on the chord root and does not move with your voice like the other voicings.

Scalic harmonies allow you to choose intervals that belong to the scale type only. The same ranges apply (plus or minus 2 octaves). There is no bass voicing in Scalic harmonies.

Chromatic harmonies allow you to choose any interval between 2 octaves up or down.

Bending (Chromatic and Scalic only)

Bending relates to pitch correction of the harmony voices and is independent of pitch bending. In Chromatic and Scalic harmony types, you have the option of pitch-correcting the harmony notes or not. When you want the harmony notes to be corrected, this is referred to as “Stepped” bending.

Because they are corrected, the harmony notes “step” up and down even when your voice is sliding between notes.

When you want the harmonies to follow your exact pitch, out-of-tune notes and all, you can set this parameter to “Smooth” bending. Smooth harmonies sound more natural and allow you to perform “Blue” notes but you must be accurate with your pitch for the harmonies to sound acceptable.

Harmony Motion (Chordal mode only)

Harmony motion gives you control over the number of “break points” in each octave. A break point is the note at which the harmony interval changes up or down depending on the voicing and the number of voices in your harmony. Normal harmony motion has more break points, creating a more active harmony part. The other option, “fixed”, reduces the number of break points to only two regardless of voicing and the number of harmony voices.

Pitch Bend

This is where you set the amount of pitch bend that can be introduced through MIDI. Each of the 8 styles can have a different range with the range being 0 to 12 semitones.

Portamento Rate

Portamento is a feature available to all harmony types that reduces the “stepping” that can occur between successive harmony notes. This can make harmonies sound more like a human singer would. Each note slides its pitch into the next at a specific rate that you determine. A small amount of portamento has been built into many of the factory programs. The values range from 0 to 10 with 10 being the slowest rate or the maximum amount of portamento.

Vocoder Mode Select (Vocoder Mode only)

There are 7 different Vocoder modes to choose from. The first 4 deal with voice assignment. In order for the Studio Vocalist EX’s intelligent Vocoder panning to work correctly, it is often necessary to limit the number of voices available to those required by your harmony part. The layered modes create thickening on single or two part harmonies. The 4 MIDI Channel mode allows individual control of each of the four harmony voices for complete pan position stability and independent pitch bend.

Transpose (Vocoder and Pitch Correct only)

In Vocoder mode, this feature allows you to transpose your harmonies +/- 3 octaves. You could use this when you are triggering your Vocoder harmonies from the bottom or top of your keyboard and the untransposed harmonies would be in the wrong octaves. The auto option allows the Studio Vocalist EX to trigger notes in the octave closest to your input note.

In Pitch Correct mode, transposing works in conjunction with MIDI or front panel keyboard input. When you sing and press a key, the resulting pitch can be transposed up to 3 octaves up or down for special effects. The auto option works as described above.

To edit the harmony style parameters:

1. Use the Data Wheel to select the program you want to edit and press the **Edit button**.
2. Press the softkey that corresponds to the Harmony parameter. The LCD shows the the current softkey selected by an arrow, its harmony style in quotation marks, and the other softkey assignments.
3. Press the softkey you wish to edit. The style display show this key's assignment.
4. Press the **Edit** button. The Harmony Type selection screen is displayed.

Your choice here affects the order and selection of editing screens because each different harmony type has its own set of parameters. Rather than explaining the location of editing screens in text, what follows is a table showing the screens in the order in which they appear.

The Arrow buttons guide you to the next or previous screen, the softkeys select the different editing fields and the Data Wheel is used to change the values.

Edit screen layout by harmony type:

CHROMATIC:

Harmony Type : Voicing : Bending : Pitch Bend : Portamento Rate : Customize : Style Name

SCALIC:

Voicing : Bending : Pitch Bend : Portamento Rate : Customize : Style Name

CHORDAL:

Voicing : Harmony Motion : Pitch Bend : Portamento Rate : Customize : Style Name

VOCODER:

Vocoder Mode : Transpose : Pitch Bend : Portamento Rate : Style Name

PITCH CORRECT:

Transpose : Pitch Bend : Portamento Rate : Style Name

When you are satisfied, press **Store** once or **Exit** twice to save your changes. See “Storing Your Edits” at the end of this chapter for more details on saving.

Level 3: Customizing A Harmony

Customizing allows you to determine exactly which notes are produced for any given input note. It is the deepest harmony editing level and it is only available with Chordal, Scalic and Chromatic harmony types.

Custom harmony variations are used in the Everlys program and many of the other Scalic harmony programs. These harmony styles are based on a major or minor Scalic harmony that has been edited so that certain input notes produce different harmonies from those in the strict definition of a these scales.

Once you have customized a harmony, the Voicing edit screen disappears and is replaced by the Customize Voicing screens. The Customize Voicing screens work differently in that you have all twelve notes of the scale to apply to input notes where you previously could choose only the notes within a major or minor scale for Scalics and notes from a particular chord in Chordal harmonies.

The Custom Harmonies screens are as follows:

Custom Voicing

You have a range of twelve input notes within one octave to assign alternative harmony voicings to. You can, however, choose any of the notes within a four octave range to apply to the input notes in your octave.

You also have the option of inserting a “no change” shown by “n/c” in the Custom Voicing screen. This is a way of handling non-scale or non-chord notes gracefully and to control harmony motion. Instead of assigning a particular note, you can assign a “no change” which locks the harmony note on the previous one regardless of whether it was higher or lower. In fact, “no change” forms the basis for the Chordal harmony concept where the harmony notes are confined to two or three notes per octave for any of twelve input notes.

Custom Harmony Key

You must tell the Studio Vocalist EX what key your input notes are referenced to before you begin customizing. The default key from the factory is C but you can change it to any of the 12 keys.

To make your own custom harmony:

1. Select a program with harmony styles close to what you want and press the **Edit** button.
2. Press the softkey that corresponds to Harmony. Select the harmony style closest to what you want. This will save you extra effort.
3. Press the **Edit** button.
4. Press the Left Arrow button twice to locate the “[Edit] to Customize” screen. Press the **Edit** button. This presents the Custom Harmony Voicing screen showing the note assignments for the harmony style you have chosen.
5. Use the softkeys to select each of the four voices for editing and use the Data Wheel to change the voicings.
6. Press the **Store** button to save your new harmony style. Remember, you have to assign this new style to the current program; it is not done automatically.

Note: If you want to reference your harmonies to any other key than C, press the Right Arrow button to present the Custom Harmony Key reference setting screen. Use the Data Wheel to change to the new key.

Naming Your Programs and Styles

When you have completed your editing you have the option of modifying or creating a 16 character name for the program. Fifteen character style names are available for harmony styles as well. The humanizing styles can also be named but with 10 character names only.

You may use a mixture of upper and lower case letters, numbers and symbols for naming. If you want to enter a letter in a blank space, the default assignment is from the lower case alphabet. Also included are insert and delete functions to speed naming.

To change a Program or Style name:

1. Select the program or style you want to rename and press the **Edit button**.
2. For programs, press the softkey that corresponds to Name. For styles, press the Left Arrow button. The naming screen will be shown in the LCD.
3. Select a character type from the top row of softkeys. These are upper (uppr) and lower (lowr) case characters, numbers (numr) and symbols (symb). The default for a blank space is lower case. The bottom row of softkeys controls cursor left (<<<) and right (>>>) movement and allows you to insert or delete characters at the cursor position.
4. Spin the Data Wheel to change the character underscored by the cursor.
5. Press **Store** to save your changes or press the Program button to cancel your changes and return to the top level.

Storing your Edits

There are two ways to save your edits using the Store function:

1. Program Store - This is the term for saving any change you make such as attaching a different humanizing style to a program, loading different harmony styles or changing the mix. Factory programs cannot be overwritten; they can only be copied to the user bank where any changes are stored permanently.
2. Style Store - This is the term for saving an edited version of a humanizing or harmony style. Styles are stored independently of programs and are stored in a separate library to be shared by the programs. Factory styles cannot be over-written after they have been modified; they can only be copied to user locations.

Note: If you have edited and saved a style to the user bank, it is not permanently attached to the current program until you perform a Program Store.

To store programs to the user bank: (Program Store)

1. When you are satisfied with your editing, press the **Store** button. A Program Store is initiated from either the Performance (top) layer or the Select Parameter layer.
2. The LCD shows that the new program name is the same as the current name. It also shows that the Studio Vocalist EX has automatically chosen the next blank user slot to store the new program to.

3. Press **Store** again to accept the default name and destination. If you want to, you can change the destination with the Data Wheel.

To store styles to the user bank: (Style Store)

1. After editing the parameters of a style, press the **Store** button. A Style Store is initiated only from Style Modify layer.
2. The LCD will show that the new style name is the same as the current with a “■” character tagged onto the end. It will also show that the Studio Vocalist EX has automatically chosen the next blank user slot to store the new style to.
3. Press **Store** again to accept the default name and destination. If you want, you can change the destination with the Data Wheel.
4. Press **Exit**.
5. Follow the Program Store procedure to attach the new style to your program permanently.

Note: Once you have built up your own library of new styles, keep in mind that when you modify a style that is shared by more than one program, you are making changes to all of these programs. When you choose to edit and store a user style, the store screen will tell you whether other programs are sharing this style.

UTILITIES

Overview

The Utilities mode allows you to make global (affecting all programs) configuration changes to the Studio Vocalist EX, including MIDI channel assignments, audio configurations, program, song and style initialization and user preferences.

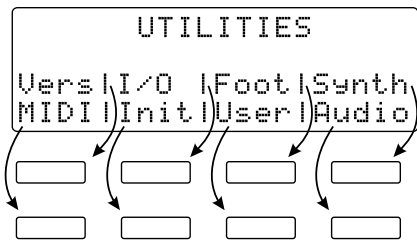

To enter and exit Utilities mode:

Press the Utilities button in any of the other operating modes including Programs, Edit, and Songs modes. Once you have altered one of the configuration settings, you can press the Utilities button again to exit to the screen you started from. For example, this makes it convenient during editing to change MIDI channel assignments.

To select one of the configuration menus:

After entering Utilities mode, you can select the configuration menu you need from the softkeys.

Version Display

This is represented by the abbreviation **Vers**. Pressing this soft key produces the introduction screen as shown when the product is first powered up. Displayed on the second line of this screen is the software version number. The software version number indicates whether software updates, if any, have occurred.

MIDI

Pressing the MIDI soft key within Utilities mode presents the MIDI Utilities sub menu. From this screen you can choose a MIDI Utility to modify.

MIDI Channel Select

To provide maximum flexibility and to reduce conflicts, the Studio Vocalist EX can control the channel assignments of more than just the usual program changes and continuous controllers. There are three areas in the Studio Vocalist EX that can have their own MIDI channel assignments if required.

The **System & Vocoder** channel determines which channel program changes, continuous controller (Pitch Bend, Modulation etc.) and single-channel Vocoder messages are received upon. When you use the 4 channel Vocoder mode, the System & Vocoder setting determines the channel for voice one only.

Note: If you decide to use the option of accessing styles by MIDI *program changes*, the key and harmony channel should be set to a different channel than the system channel to avoid conflicts between loading programs and loading harmony styles.

The **Key & Harmony** channel allows you to select different keys or chords (depending on the harmony type) and any of the eight different harmony styles assigned to a program via MIDI.

The **4 MIDI Channel Vocoder** setting allows each of the four individual voices to have its own channel when using the “4MID” Vocoder style within any Vocoder program. Assigning each voice its own MIDI channel and using the program stops “voice swapping” which causes voices panned in the stereo field to switch positions. If you run in mono, or stereo mode and you don’t mind the voice swapping, you can use a “4MID” Vocoder style on the same MIDI channel as the system.

The 4 channel Vocoder mode also allows you to use separate pitch bending on each of the four voices.

Voice one in 4 channel Vocoder mode is always the same as the System & Vocoder channel. The remaining three voices are set independently.

To change the System & Vocoder and Key & Harmony MIDI channels:

1. Press the Utilities button from any mode. This presents the UTILITIES main menu.
2. Press the soft key corresponding to **MIDI**. This presents the MIDI Utilities sub-menu.
3. Press the soft key corresponding to **Channel**.
4. Select either System & Vocoder or Key & Harmony by pressing the corresponding softkeys below the options. Turn the Data Wheel or use the upper and lower softkeys to select the desired channel. Selecting the “off” option disables the MIDI program change feature. Selecting the “omni” option causes the Studio Vocalist EX to respond to MIDI messages on all 16 MIDI channels.
5. Press the Utilities button again to exit. This returns you to the mode from which you entered.

To change the Vocoder MIDI channel(s):

1. Press the Utilities button from any mode. This presents the UTILITIES main menu.
2. Press the soft key corresponding to **MIDI**. This presents the MIDI Utilities sub-menu.
3. Press the soft key corresponding to **Channel**.
4. Press the Right Arrow button.
5. You can select Vocoder voices 2, 3 and 4 using the softkeys below them. Voice 1 follows the system channel and cannot be changed in this screen. The channel settings can be changed with the upper and lower softkeys or the Data Wheel.

Selecting the “off” option by turning the Data Wheel to the right disables external control of the Vocoder. Selecting the “omni” option causes the Vocoder to respond to notes on any and all MIDI channels.

6. Press the Utilities button again to exit. This returns you to the mode from which you entered.

MIDI Selection of Key & Harmony

Controlling your harmonies can be done through MIDI as an alternative to using the front panel. You have the option of independently selecting key or chord root and style. There are several ways in which this can be done to provide you the most flexibility in live performance or sequencing.

MIDI options for selecting key and harmony style:

- Chord Recognition
- Controller #16 (transmitted from front panel)
- Notes
- Program Change

Using **Chord Recognition** and a Chordal harmony program is the most useful combination when you want to just “plug in and play”. The chord voicings you use in your playing are interpreted by the Studio Vocalist EX as key and harmony information. You can also set chord recognition so that it only recognizes chords played on the upper or lower part of your keyboard with a split point that you set. This way, left hand bass lines don’t cause the harmonies to jump around. See page 39 for more information on setting the split point.

The program you have loaded must contain styles that are related to the chords you play. As an example, if you play a C augmented 7th chord and the Studio Vocalist EX program has no augmented 7th styles the Studio Vocalist EX selects the closest sounding chord. See the Harmony Editing section on page 26 for instructions on adding or modifying chord styles.

Controller 16 is a MIDI continuous controller that can be used to select key and harmony together. The Studio Vocalist EX's front panel keyboard and softkeys transmit this information over MIDI when you press them and can be recorded and played back from a sequencer. Each button has its own CC16 value and is shown in the following graphic:

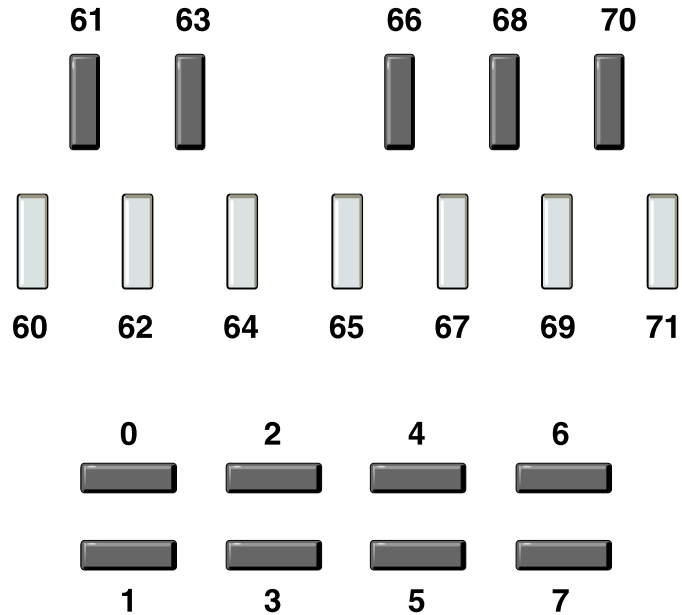

MIDI Notes give you another way to combine program changes and key and harmony changes into one MIDI channel. Each MIDI note in the following reference table represents both a key and a style in a single message. Select your key or chord root from the octave matched to the soft-key you want.

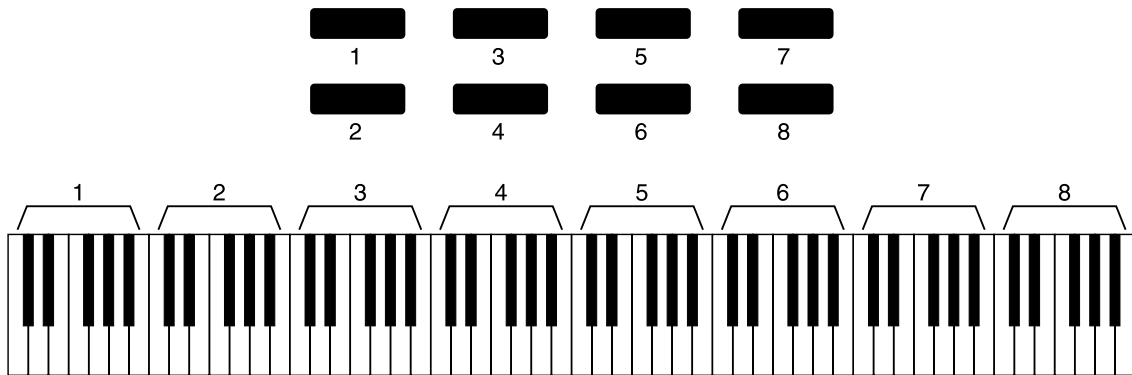

Program Change messages can also be used to select key and harmony simultaneously. The following table shows how they are assigned. The top row represents the softkeys, the keyboard represents the chord root or key and the table shows the resulting program change number.

B	12	24	36	48	60	72	84	96
B#	11	23	35	47	59	71	83	95
A	10	22	34	46	58	70	82	94
A#	9	20	33	45	57	69	81	93
G	8	20	32	44	56	68	80	92
F#	7	19	31	43	55	67	79	91
F	6	18	30	42	54	66	78	90
E	5	17	29	41	53	65	77	89
E#	4	16	28	40	52	64	76	88
D	3	15	27	39	51	63	75	87
C#	2	14	26	38	50	62	74	86
C	1	13	25	37	49	61	73	85

To choose MIDI Key & Harmony options:

1. Press the Utilities button from any mode. This presents the UTILITIES main menu.
2. Press the soft key corresponding to **MIDI**. This presents the MIDI Utilities sub-menu.
3. Press the soft key corresponding to **Key & Harmony**.
4. The first page allows you to set the receive and transmit options with the Data Wheel.
5. Press the Right Arrow button to change between Chord Recognition+CC16, Program Change, and Notes with the Data Wheel.
6. Press the Right Arrow button again to set the keyboard split point for chord recognition. The softkeys are used to select the “above” or “below” options and the split point note selection.
7. Press the Utilities button to exit to the previous mode.

MIDI Continuous Controllers (CC)

The Studio Vocalist EX responds to MIDI CC messages like any synthesizer module. This section of the Utilities menu allows you to remap which MIDI controllers affect Studio Vocalist EX parameters. Any of the 120 MIDI continuous controllers and Aftertouch (which is not an official CC) can control the Studio Vocalist EX. You can also select “none,” which disables MIDI control of any parameter.

A continuous controller is a specific type of message transmitted by a MIDI keyboard. You are transmitting CC’s for example, when you move your pitch bend or modulation wheels, press down harder on the keys or

Note: All CC's except Volume (CC7) reset to their default values when a MIDI program change message is received.

blow into a breath control device. It is with CC's that you introduce dynamics and emotion into your harmony performance.

Studio Vocalist EX parameters you can modify by continuous control and their default MIDI mappings:

- Volume to MIDI Volume (CC 7)
- Detune to Expression Controller (CC 11)
- Vibrato Depth to Modulation Wheel (CC 1)
- Vibrato Rate to Effect Control 1 (CC 12)
- Harmony Hold to Effect Control 2 (CC 13)

The **Harmony Hold** works with Chordal and Scalic harmony programs to freeze the current harmonies while you continue to sing notes that would otherwise cause the harmonies to change. It's useful when you want to throw some vocal "riffs" in a part of song and don't want the harmonies to follow.

To change the Continuous Controller mapping:

1. Press the Utilities button from any mode. This presents the UTILITIES main menu.
2. Press the soft key corresponding to **MIDI**. This presents the MIDI Utilities sub-menu.
3. Press the soft key corresponding to **CC**.
4. Use the softkeys to select one of the three editable fields in the MIDI Controllers screen: the internal parameter you want to control, the CC that controls it and the control polarity. The control polarity can be used to reverse the response of the controller.
5. Press the Utilities button to exit to the previous mode.

MIDI Program Change mapping

Incoming MIDI Program Change messages can be remapped to any of the Studio Vocalist EX's internal programs. Remapping simply means that when you send the product a MIDI program change number 1, you have the option of making that number call up some other program instead. This allows the product to adapt to existing program changes in MIDI sequences or MIDI performance controllers.

Any incoming Program Change command can be:

- Mapped to the same program number in the Studio Vocalist EX
- Mapped to any other program number
- Mapped to enable Bypass mode
- Ignored by the Studio Vocalist EX (no change from previously loaded program)

This utility can also control the reception and transmission of program changes. This is handy if you want the Studio Vocalist EX to retransmit any program remappings you have created. These messages are sent from the MIDI Output jack

The program change receive and transmit options are:

- Off Ignore MIDI program changes
- Receive only Enable external MIDI program changes
- Transmit only Transmit front panel program changes
- Receive and transmit Receive external and send remapped programs

To edit the MIDI Program Change mapping:

1. Press the Utilities button from any mode. This presents the UTILITIES main menu.
2. Press the soft key corresponding to **MIDI**. This presents the MIDI Utilities sub-menu.
3. Press the soft key corresponding to **Program** then the Left Arrow button. This shows the MIDI Program Mapping screen with the mapping for internal program number 1.
4. Use the Data Wheel to scroll through the *incoming* program numbers and find the one you would like remapped. The display shows the names of the internal programs these numbers are currently mapped to.
5. Press a soft key under the “maps to” prompt to move the brackets to the *internal* program selection field. Use the Data Wheel to scroll through the program numbers.
6. Press Utilities button to exit to previous mode.

To configure Program Change receive and transmit options:

1. Enter Utilities and MIDI program Change mode as above.
2. Use the Data Wheel to scroll through the options explained above.
3. Press Utilities button to exit to previous mode.

Vocoder keyboard split point

You can define the area of your controller keyboard that triggers Vocoder notes. You can choose which half of your keyboard generates Vocoder harmonies and where the split point is. Setting the Vocoder to respond only to the top half of your keyboard could help when you are playing left-handed bass lines and don't want them interfering with your Vocoder harmonies. You could also set the Studio Vocalist EX to respond only to the lower octaves if you are performing right-handed melody lines and you would like to hold Vocoder chords with your left.

5. Use the Data Wheel to select the desired Song Step option.
6. Press the Utilities button once again to exit; this returns you to the mode from which you entered.

Song Step Direction can be controlled in various ways. The Studio Vocalist EX's Song Step Forward messages can be assigned to MIDI Continuous Controller number 17, or any MIDI note from C -1 to G 9. Song Step Backward messages can be assigned to MIDI Continuous Controller 18, or any MIDI note from C -1 to G 9. If MIDI notes are used to control song steps, be sure to assign unique notes to the forward and backward directions to avoid conflicts.

The Song Step direction control options are:

- CC17 (value equals # of Steps) Step forward
- CC18 (value equals # of Steps) Step back
- MIDI Notes (any two) Step forward and back

To change the MIDI Song Step direction:

1. Press the Utilities button from any mode; this presents the UTILITIES main menu.
2. Press the MIDI softkey; this presents the MIDI Utilities sub-menu.
3. Press the softkey corresponding to Song.
4. Press the Right Arrow button three times.
5. Use the softkeys to select Forward or Backward direction fields and the Data Wheel to select the desired controller.
6. Press the Utilities button once again to exit; this will return you to the mode from which you entered.

MIDI Dump Utilities

Note - Supporting earlier DigiTech Harmony products: To maintain compatibility with earlier products, the Studio Vocalist EX is able to receive a single program dump from a Studio Vocalist or a Vocalist Workstation. Consult the appropriate owner's manual for dump procedure.

The Studio Vocalist EX's MIDI Dump Utilities allow you transmit programs, songs, and utility settings as MIDI system exclusive messages to other Studio Vocalist EXs, or computer-based sysex (system exclusive) librarian programs for future retrieval.

To dump a single program to another Studio Vocalist EX

1. Press the Utilities button from any mode; this presents the UTILITIES main menu.
2. Press the MIDI softkey; this presents the MIDI Utilities sub-menu. The display will read "Press Store to dump SVex program".
3. Press the softkey corresponding to **Dump**.
4. Use the Data Wheel to select the desired program to dump.
5. Press the **Store** button to dump the program; the unit will display "Dumping...completed" after about one second to indicate that the dump is finished.
6. Press the Utilities button once again to exit; this will return you to the mode from which you entered.

To dump a single program to an original Studio Vocalist (non-EX):

1. Press the Utilities button from any mode; this presents the UTILITIES main menu.
2. Press the MIDI softkey; this presents the MIDI Utilities sub-menu.
3. Press the softkey corresponding to **Dump**.
4. Press the Right Arrow button once. The display will read “ Press [Store] to dump SV V1.0 program.
5. Use the Data Wheel to select the desired program to dump
6. Press the **Store** button to dump the program; the unit will display “Dumping...completed” after about one second to indicate that the dump is finished.
7. Press the Utilities button once again to exit; this will return you to the mode from which you entered.

To dump all programs (bulk dump) to another Studio Vocalist EX:

Note- Studio Vocalist EX and Vocalist Workstation Compatibility: You may perform single program dumps between these two products only. The bulk dump feature will not work.

1. Press the Utilities button from any mode; this presents the UTILITIES main menu.
2. Press the MIDI softkey; this presents the MIDI Utilities sub-menu. If you are dumping all programs to a sysex librarian, ensure that the librarian is ready to receive a sysex dump.
3. Press the softkey corresponding to **Dump**.
4. Press the Right Arrow button twice.
5. Press the **Store** button to dump all programs; the unit will display “Dumping...” while the dump is in progress. When the dump has been transmitted in full, the unit will display “Dumping...completed”. The time required to perform a bulk dump will vary with the number of programs, styles and songs stored in the unit at any given time. Typically, a bulk dump will take about ten seconds to complete.
6. Press the Utilities button once again to exit; this will return you to the mode from which you entered.

To dump a single song to another Studio Vocalist EX:

1. Press the Utilities button from any mode; this presents the UTILITIES main menu.
2. Press the MIDI softkey; this presents the MIDI Utilities sub-menu. If you are dumping the song to a sysex librarian, ensure that the librarian is ready to receive a sysex dump.
3. Press the softkey corresponding to **Dump**.
4. Press the Right Arrow button three times.
5. Use the Data Wheel to select the desired song to dump.
6. Press the **Store** button to dump the song; the unit will display “Dumping...completed” after about one second to indicate that the dump is finished.
7. Press the Utilities button once again to exit; this will return you to the mode from which you entered.

To dump all songs to another Studio Vocalist EX:

1. Press the Utilities button from any mode; this presents the UTILITIES main menu.
2. Press the MIDI softkey; this presents the MIDI Utilities sub-menu. If you are dumping all programs to a sysex librarian, ensure that the librarian is ready to receive a sysex dump.
3. Press the softkey corresponding to **Dump**.
4. Press the Right Arrow button four times.
5. Press the **Store** button to dump all songs; the unit will display “Dumping...” while the dump is in progress. When the dump has been transmitted in full, the unit will display “Dumping...completed”.
6. Press the Utilities button once again to exit; this will return you to the mode from which you entered.

The Studio Vocalist EX’s MIDI Dump Utilities also allow you to dump all utility settings; this includes all global parameters as well as Continuous Controller, Program Select, and Song Select mappings.

To dump utility settings to another Studio Vocalist EX:

1. Press the Utilities button from any mode; this presents the UTILITIES main menu.
2. Press the MIDI softkey; this presents the MIDI Utilities sub-menu. If you are dumping all programs to a sysex librarian, ensure that the librarian is ready to receive a sysex dump.
3. Press the softkey corresponding to **Dump**.
4. Press the Right Arrow button five times.
5. Press the **Store** button to dump the utility settings; the unit will display “Dumping...completed” after about one second to indicate that the dump is finished.
6. Press the Utilities button once again to exit; this will return you to the mode from which you entered.

I/O Utilities (Input /Output)

Quad or Stereo Mode

The **Output Mode** selector lets you choose between stereo or quad output modes. The stereo mode assigns all outputs (dry voice plus harmony voices) to the left and right rear-panel outputs, with the associated pan values defined in the current program's Mix setting. The quad mode assigns all voices to individual rear-panel outputs, resulting in maximum flexibility for the recording studio.

Note that when quad output mode is enabled, the individual voice level controls remain in the Mix setting screen, but the pan control screen is eliminated.

To change between Stereo and Quad Output Modes:

1. Press the Utilities button from any mode; this presents the UTILITIES main menu.
2. Press the **Audio** softkey.
3. Press the Left Arrow button.
4. Use the Data Wheel to select the desired Output Mode.
5. Press the Utilities button once again to exit; this will return you to the mode from which you entered.

Initialization Utilities

From time to time, you may find that you have a few user programs or songs which you no longer use, or no longer want to keep. The Studio Vocalist EX's Initialization Utilities allow you to clear an unwanted program or song from memory, resulting in a "clean slate" from which you can create a new one. Note that once a program or song is initialized, it is gone for good! If you want to save your program or song before initializing it, dump it via MIDI either to another Studio Vocalist EX or a sysex librarian program for later retrieval. (Refer to the MIDI Dump Utilities section above for help.)

An easy way to free up memory in your Studio Vocalist EX is to occasionally initialize all unused user styles. This procedure will initialize only the styles which are currently not used by any program, so there is no danger of changing the sound of existing programs. Initializing unused styles periodically as a "routine maintenance" activity will ensure that you always have some available memory with which to create and store new styles.

You also have the option of restoring all factory programs, styles and songs (factory restore). This option should be used cautiously, since all user programs, styles and songs are erased in this procedure! Use the factory restore option only if you are sure that you wish to return the Studio Vocalist EX to its initial factory state.

Pressing the Init softkey from within the Utilities mode presents the Initialize Utilities sub menu.

*From the **Init** screen you can choose to initialize:*

- a user Program
- any Song
- all unused styles
- all programs, styles and songs (factory restore)

To initialize (clear) a user program:

1. Press the Utilities button from any mode; this presents the UTILITIES main menu.
2. Press the **Init** softkey; this presents the Initialize Utilities sub-menu.
3. Press the softkey corresponding to **Programs**.
4. Use the Data Wheel to select the program to initialize.
5. Press the **Store** button to initialize the program; the unit will respond with “Prog Init complete”.
6. Press the Utilities button once again to exit; this will return you to the mode from which you entered.

To initialize a song:

1. Press the Utilities button from any mode; this presents the UTILITIES main menu.
2. Press the **Init** softkey; this presents the Initialize Utilities sub-menu.
3. Press the softkey corresponding to **Song**.
4. Use the Data Wheel to select the song to initialize.
5. Press the **Store** button to initialize the song; the unit will respond with “Song Init complete”.
6. Press the Utilities button once again to exit; this will return you to the mode from which you entered.

To initialize all unused styles:

1. Press the Utilities button from any mode; this presents the UTILITIES main menu.
2. Press the **Init** softkey; this presents the Initialize Utilities sub-menu.
3. Press the softkey corresponding to **Style**.
4. Press the **Store** button to initialize all unused styles; the unit will respond with “Style Init complete”.
5. Press the Utilities button once again to exit; this will return you to the mode from which you entered.

To initialize all programs, styles and songs (factory initialization):

1. Press the Utilities button from any mode; this presents the UTILITIES main menu.
2. Press the **Init** softkey; this presents the Initialize Utilities sub-menu.
3. Press the softkey corresponding to **All**.
4. Press the **Store** button. A warning tells you that all user programs, songs and styles will be lost. To cancel the factory initialization, press the **Exit** button; otherwise, press the **Store** button to perform the initialization. During the initialization process the version screen will appear; when initialization is complete, factory program F 1 will be loaded and the unit is ready to use.

Footswitch Utilities

The Studio Vocalist EX Footswitch Utilities allow you to reconfigure the functions of the DigiTech FS300 3-button footswitch to meet your personal preferences.

Any button on the FS300 can be configured to control:

- Bypass Latching (BypL) bypass is activated when the footswitch is pressed and released, stays activated until the footswitch is pressed and released again.
- Bypass Momentary (BypM) bypass activated only while footswitch is held down.
- Program up (Pgm↑)
- Program down (Pgm↓)
- Song up (Sng↑)
- Song down (Sng↓)
- Song Step up (Stp↑)
- Song Step down (Stp↓)
- Data up (Dat↑)
- Data down (Dat↓)

Note: The Data up and down parameters allow you to duplicate the Data Wheel using your footswitch.

The default switch assignment for the FS300, from left to right, is

Program up Program down Bypass.

To change the assignment of a footswitch button:

1. Press the Utilities button from any mode; this presents the UTILITIES main menu.
2. Press the **Foot** softkey; this presents the Footswitch Controls sub-menu.
3. Press the softkey corresponding to the footswitch button to be re-assigned, either left, center or right.

4. Use the Data Wheel to select the desired footswitch action.
5. Repeat steps 3 and 4 for other button assignments, if desired.
6. Press the Utilities button once again to exit; this will return you to the mode from which you entered.

User Utilities

The User Utilities allow you to select between eight different levels of LCD display contrast, and to enable or disable voice editing of harmony intervals. Voice editing of harmony intervals needs some explanation: when editing the voicing interval or customizing a harmony style, you have the option of entering the note with the Data Wheel or by actually singing the note. The Studio Vocalist EX will recognize the note and you will see the display change to the note you have just sung.

To change the LCD display contrast:

1. Press the Utilities button from any mode; this presents the UTILITIES main menu.
2. Press the **User** softkey.
3. Use the Data Wheel to select the desired contrast level.
4. Press the Utilities button once again to exit; this will return you to the mode from which you entered.

To enable or disable voice editing of intervals:

1. Press the Utilities button from any mode; this presents the UTILITIES main menu.
2. Press the **User** softkey.
3. Press the Right Arrow button.
4. Use the Data Wheel to toggle voice editing of intervals on or off as desired.
5. Press the Utilities button once again to exit; this will return you to the mode from which you entered.

Synthesizer Mode

The Studio Vocalist EX includes an on-board synthesizer that has two modes of operation:

- It can provide a cue-in note to help you find a starting pitch to sing to.
- It can assist you in auditioning and editing programs.

Upon entering the Synthesizer screen (see below) and the synthesizer is set to Off, you can press a note on the front panel keyboard and a single

cue-in note will be produced at the outputs. This feature is only available within Utilities mode.

When you set the internal synthesizer to On, you can return to Programs mode and press any note on the front panel keyboard to play the note through the Studio Vocalist EX's pitch shifters. This will allow you to hear the harmonies currently defined for that note within the current program.

You can also adjust the output volume of the synthesizer if desired. The default volume level is -12 dB.

To activate the internal synthesizer:

1. Press the Utilities button from any mode; this presents the UTILITIES main menu.
2. Press the **Synth** softkey.
3. Use the Data Wheel to toggle the synthesizer tone on or off as desired.
4. Press the Utilities button once again to exit; this will return you to the mode from which you entered.

To adjust the synthesizer volume:

1. Press the Utilities button from any mode; this presents the UTILITIES main menu.
2. Press the **Synth** softkey.
3. Press the Right Arrow button.
4. Use the Data Wheel to set the desired synthesizer volume level.
5. Press the Utilities button once again to exit; this will return you to the mode from which you entered.

Audio Utilities

There are several important audio parameters that you can adjust to optimize the performance of the Studio Vocalist EX.

The Audio configuration parameters include:

- Ess Sensitivity
- Bass Rejection Threshold
- Harmony Gating Threshold
- Anti-feedback Control
- Tuning Reference

Ess Sensitivity

The **Ess Sensitivity** adjustment allows you to decrease the amount of sibilant energy (i.e. “ess”, “tee” and “ch” sounds) presented to the input of the Studio Vocalist EX’s pitch recognition circuitry. An increase in the Ess Sensitivity parameter increases the Studio Vocalist EX’s ability to “ignore” sibilant sounds, thereby minimizing the chance of pitch tracking errors. This setting can need to be adjusted to accommodate different singers. It is easily modified while the singer sings.

To adjust the Ess Sensitivity:

1. Press the Utilities button from any mode; this presents the UTILITIES main menu.
2. Press the **Audio** softkey.
3. Use the Data Wheel to increase or decrease the Ess Sensitivity as desired.
4. Press the Utilities button once again to exit; this will return you to the mode from which you entered.

Note: Sibilance is reduced only at the Studio Vocalist EX’s pitch recognition circuitry and not in the audio path. The frequency response of the input voice is not affected.

Bass Rejection

The **Bass Rejection** Threshold control is used to increase the Studio Vocalist EX’s immunity to pitch tracking errors caused by low frequency noise at the input. Increasing the Bass Rejection Threshold is useful for filtering out wind, background, or microphone handling noise. Once again, the frequency response of the audio path is not affected.

To adjust the Bass Rejection Threshold:

1. Press the Utilities button from any mode; this presents the UTILITIES main menu.
2. Press the **Audio** softkey.
3. Press the Right Arrow button.
4. Use the Data Wheel to increase or decrease the Bass Rejection Threshold as desired.
5. Press the Utilities button once again to exit; this will return you to the mode from which you entered.

Harmony Gating Threshold

The Harmony Gating Threshold allows you to set the level which the input voice must exceed in order for the harmonies to turn on. This can be a handy adjustment for live performance, where the sound from other instruments can interfere with the Studio Vocalist EX’s pitch recognition.

For example, if the Harmony Gating Threshold is set at -20 dB, then any background or stage noise at a level less than -20 dB, according to the Studio Vocalist EX’s front-panel input level meters, will not cause the harmonies to be enabled; the dry signal is output normally. Once the input level exceeds -20 dB (i.e. the singer sings into the microphone), the Studio Vocalist EX will lock on to the voice and the harmonies will be

added to the dry voice in the audio outputs. Once the input level again drops to less than -20 dB, the harmonies will be disabled and removed from the audio outputs.

To adjust the Harmony Gating Threshold:

1. Press the Utilities button from any mode; this presents the UTILITIES main menu.
2. Press the **Audio** softkey.
3. Press the Right Arrow button twice.
4. Use the Data Wheel to increase or decrease the Harmony Gating Threshold as desired.
5. Press the Utilities button once again to exit; this will return you to the mode from which you entered.

Anti-feedback Control

The **Anti-feedback Control** is useful for reducing high frequency feedback in live or other high volume applications. Increasing the value of the Anti-Feedback control attenuates sibilant sounds in the audio path.

To adjust the Anti-feedback Control:

1. Press the Utilities button from any mode; this presents the UTILITIES main menu.
2. Press the **Audio** softkey.
3. Press the Right Arrow button three times.
4. Use the Data Wheel to increase or decrease the Anti-feedback Control as desired.
5. Press the Utilities button once again to exit; this will return you to the mode from which you entered.

Tuning Reference

The **Tuning Reference** in the Studio Vocalist EX can be adjusted + or - 100 cents (one semitone) from a base reference of A = 440 Hz.

To change the Tuning Reference:

1. Press the Utilities button from any mode; this presents the UTILITIES main menu.
2. Press the **Audio** softkey.
3. Press the Left Arrow (<) button twice.
4. Use the Data Wheel to set the Tuning Reference as desired.
5. Press the Utilities button once again to exit; this will return you to the mode from which you entered

SONG MODE

The Song mode is a handy and effective tool for live performance that enables you to switch harmony styles “on the fly”. Song mode also provides a convenient way to select key or chord change sequences from a Digitech FS300 footswitch. Choose different Styles, scales or special effects by entering them into a list that can be stepped through, almost like a manual sequencer. For example, you could assign “Silky Thickener” to the first verse, “Everlys” to the second verse, “Eagles” to the chorus and “Manhattan” to the bridge. The Song mode of the Studio Vocalist EX song is arranged into sections in the same way as most popular songs. You construct each song from the building blocks of verse, bridge, chorus etc. and then place them in the order you want. You can create your own customized song list in any of the 50 song presets.

Song mode also lets you program chord changes which are needed in the Chordal mode if you are not using MIDI. Simply press the FS300 footswitch at the correct musical points to step through the changes in real time. Alternatively, MIDI can also be used to control the steps of Song playback.

Playing the Demo Songs

Pressing the Songs button presents the Song Performance screen which will show you the information for the demonstration songs.

Song Title	"Amazing Grace	"F	Starting Key
Section Name	←A: Verse	Step: 1→	Step Number
Program # and Name	F21 OAKRIDGE	C	
Chord Root or Key	F maj	3Fixed+Bass	Harmony Variation

Song mode performance controls from the front panel:

- The Data Wheel is used to load songs
- The Arrow buttons and footswitch are used to step forward and backward through the song sections.

Song mode control options using the footswitch:

- Song up and down
- Song step up and down

These options are configured in the Utilities menu under the **Foot** softkey.

You can step through the demo songs with the footswitch or Arrow keys to familiarize yourself with Songs mode. Choose a song you are familiar with and sing it while you step through the chord changes. As you step through the songs, you will hear and see the step number increment and the current chord names and styles change. Depending on

which demo song you have chosen, you may see the program change also.

Creating Your Own Songs

The arrangement and section editing screens in Song mode make it easy to create your own songs for non-MIDI performance. Each song in the Studio Vocalist EX is made up of up to 16 different sections with a choice of preset names such as Verse, Chorus etc.. Each section can consist of up to 32 different steps and these are the actual chord, key or program changes that make up a song. A song can be as simple as a single section with 4 chord changes in it or as complex as multiple verse, chorus, and bridge sections each with numerous chord and program changes.

The beauty of this format is that it is easier to build a song up in sections in no particular order and piece them together in the arrangement screen. This is especially useful for songwriting where the arrangement of verse, chorus and bridge is likely to change.

To create a new song section:

1. Press the **Songs** button. This presents the Performance screen.
2. Turn the Data Wheel to locate a blank song. The song name “Blank Song...#” will show in the LCD and the Bypass LED will light. The Bypass LED always lights at the end of a section.
3. Press the **Edit** button. This presents the Arrangement editing screen. (The screen shown below represents what the screen will look like after the changes outlined below have been made)

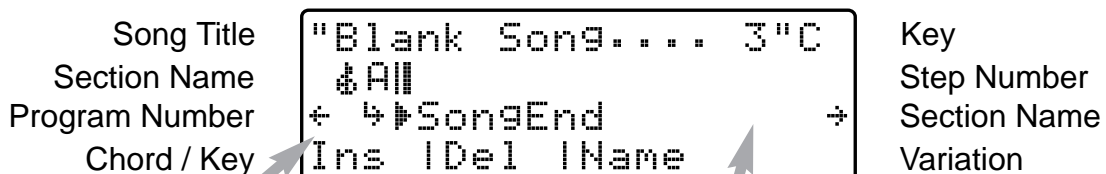

4. Use the front panel keyboard to input the key you want your song to be in. If set incorrectly, this will be confusing later.
5. Press the **Insert** softkey once. The letter “A” appears as the first section in the song. If you turn the Data Wheel, you can change the letter assignment for this section. If you press the right Arrow button, the arrow moves to select the ending marker. Return the arrow so it is beneath the letter and set the letter to “A”.
6. Press the **Edit** button again. This will show the Section editing screen.

Section Letter
Step Number
Program Number
Step Insert/Delete

```
Section:A Sec. Name  
←Step 1: C maj →  
F # Program Name  
Ins IDel IName
```

Key or Chord
Program Name
Name Editor

6. Press the **Insert** softkey to add a new step to your section. This presents the Step Insert screen. In this screen you can choose a different chord root or key, harmony style and program for each step in this section.
7. Turn the Data Wheel to select the program you want for this step. Select the chord root or key from the front panel keyboard and the harmony style from the softkeys

Tip: You can simplify this step by selecting your chords on a MIDI keyboard and pressing the Step ↑ footswitch button to enter them.

8. Press the Right Arrow button to insert another event into your section. The number at the top left of the screen will increase by one. Since you have entered a program you like in the previous step, you only need to enter the chord root, key or harmony style.
9. Press the Right Arrow button to enter new steps as they are required. If you make a mistake, it can be repaired in the Step Edit screen only (see below).
10. Press the **Exit** button to review your work in the Section Edit screen. Sing this part of your song and use the Arrow buttons or the footswitch to take you forward and back through the steps. If you have missed a chord, press **Insert** and add it as before. If you have more steps than you need or an incorrect entry, press the **Delete** softkey.

Note: Insert adds a new step before the current one shown on the screen. Delete removes the current step and replaces it with the one following.

Editing Your Steps

If you would like to change something you entered in the Step Insert screen, this can be done in the Step Edit screen. This will allow you to modify chord root, harmony style, key and programs only. You cannot insert or delete events as you can in the Step Insert screen.

It is helpful to know the section and step number before you enter the Step Edit screen. Advance through the steps in the Performance or Section Edit screens taking note of where your change will be required.

To modify a song step:

1. From the Arrangement screen, select the section you want to edit with the Arrow buttons. Press the **Edit** button. This presents the Step Insert screen.
2. Press the **Edit** button again. This presents the Step Edit screen.
3. Locate the step you want to change with the Arrow buttons. The step number at the top left of the LCD will show you where you are.

4. Use the Data Wheel, softkeys and keyboard to enter the new information. The Arrow buttons are still active so you can make changes to additional steps.
5. Press the **Exit** button twice to exit and store your changes if you decide to keep them.

Naming Songs and Sections

Naming your song is important for your reference but not required by the Studio Vocalist EX.

If you plan to use the Arrangement editing feature you should assign each section a name such as verse, chorus etc.. This will make it easier to know where you are in performance and when it comes time to put the sections together into an arrangement. To save you typing in each section name, we have given you factory names from which you can choose.

To name a song:

1. Press the **Songs** button to enter Songs mode, and select the desired song # with the Data Wheel.
2. Press the **Edit** button once.
3. Press the **Name** softkey.
4. The current name is shown on the second line. The softkeys are used to move the cursor and to enter letters, numbers and symbols and the Data Wheel is used to select data.
5. Press the **Exit** button twice and then **Store**; or **Exit** then **Store** to save your changes.

To name a song section:

1. Press the **Songs** button to enter Songs mode.
2. Press the **Edit** button once.
3. Press the **Right** and **Left Arrow** buttons to locate which section you want to name.
4. Press the **Edit** button.
5. Press the **Name** softkey. This presents the section naming screen.
6. Turn the Data Wheel to select the predefined name you want to assign to the current section.
7. Press the **Exit** button twice and then **Store** to save your changes, or the screen-labeled softkeys to discard edits. Press **Exit** to return to Songs mode..

You have now created the first building block of a song. Depending on the complexity of your song, you may be finished with programming at this point.

If, however, you have other parts of your song you would like harmonies in, you will probably want to create some more sections and then piece them together in the Arrangement editing screen.

To create more sections:

1. Repeat steps 1 to 4 above. Make sure to load the song you have just started even though it may still be called “Blank song #”.
2. Press the **Insert** softkey to add another section.
3. Turn the Data Wheel one notch to the right. This selects your new section for editing and change its letter assignment to “B”.
4. Press the **Edit** button to enter the Section edit screen. Proceed as described previously.

Arranging your song

If you are following the preceding instructions, you will have a couple of sections named A and B in no particular order. To make it easier to execute a song in performance, you need to order the sections so you only have to press the Step Up footswitch to advance through the steps. This is where you need the Arrangement editing screen.

You need to know the arrangement of the song you are copying from or creating. It might be helpful to jot it down on a piece of paper. Start by writing down the whole song, even the parts that don't have harmonies, in verse/chorus/verse/chorus form. This helps considerably when you are in the Arrangement editing screen.

To arrange the parts of your song:

1. Create at least two song sections as described previously.
2. From the Song Performance screen (top level) press the **Edit** button to enter the Arrangement editing screen. The display shows different letter assignments for the sections you have created on the arrangement line.
3. Press the **Insert** softkey several times to put more sections into your arrangement. The arrangement line fills with “A”s.
4. Press the Right and Left Arrow to select sections that need to be changed. The bent arrow on-screen shows which section is currently selected.
5. Turn the Data Wheel to change the current section assignment. Repeat this procedure until you have programmed your complete arrangement.
6. Press the **Exit** button. This initiates the Store screen. You can choose to store your song in any location by turning the Data Wheel.

Changing Song Keys (Transposing)

If you want to change the key of your song to accommodate a different singer or a sore throat, you can do so with the Song Transpose feature. All of the chords in your songs will automatically shift to the new key and you can decide whether to temporarily change the key or make the change permanent.

To change the key of your song:

1. Press the **Songs** button to enter Songs mode, and use the Data Wheel to select the desired song.
2. Press the **Edit** button once.
3. Press the note on the front panel keyboard that corresponds to the new key. To check the new key, press exit twice to bring you to the Performance screen where you can step through the song.
4. To save the key change press the **Store** button twice. If you do not save the change, the last changes will disappear when you load another song or power the unit off.

BASIC HARMONY CONCEPTS

Overview

A well-crafted vocal harmony can do a great deal towards enhancing a musical selection. The contrast between a lone singing voice and a group of voices signing together makes the music that much more interesting.

But harmonies can be somewhat difficult to understand, so in this chapter, we will try and demystify this process. Discussed will be the concept of “musically correct” harmonies and the difference between the two essential harmony types utilized by the Studio Vocalist EX: Chordal harmony and Scalic harmony.

“Musically Correct”

No, this isn't a variation of “politically correct”, but it still implies a certain level of responsibility. This responsibility is to produce a combination of notes that is pleasing to sensibilities accustomed to the western twelve tone scale.

Harmonies that are “correct” are referred to as being “Diatonic” which is defined as:

- any melody or group of chords that conforms to a single scale or key.

To illustrate this, see the C major scale below. Whether you studied music or not, you've no doubt heard it somewhere and could probably sing it from memory.

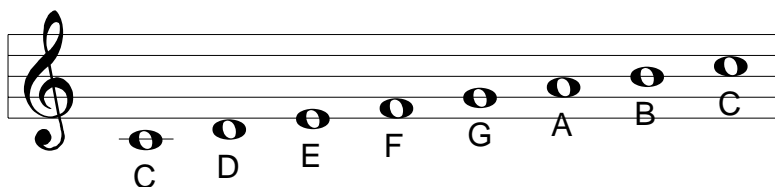

A diatonic, correct harmony could be shown by simply taking all the notes in this scale and moving them up one line on the staff. Notice in the example below of a 3rd above harmony that the harmony notes shown in grey belong to the scale.

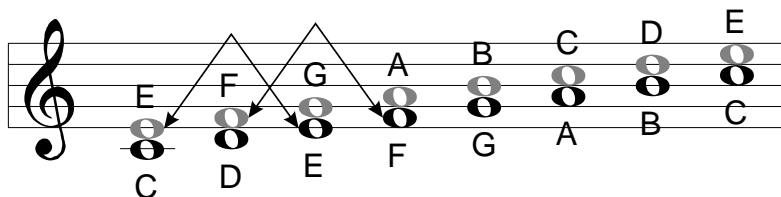

If any of the harmony notes were sharpened or flatted they would fall outside this particular scale and would not be diatonic. This theory holds for all of the different types of scales such as major, minor, diminished, augmented and wholetone.

The opposite of a diatonic harmony is chromatic. A chromatic scale is defined as:

a scale type that uses all 12 semitones.

Notice that the previous scale example had 8 notes. The chromatic scale uses all the sharp and flat notes in between as well. There are 12 of each of the major, minor, etc. scales; there is only one chromatic scale.

To illustrate a chromatic harmony, see the following example of a chromatic 3rd above harmony on our C major scale.

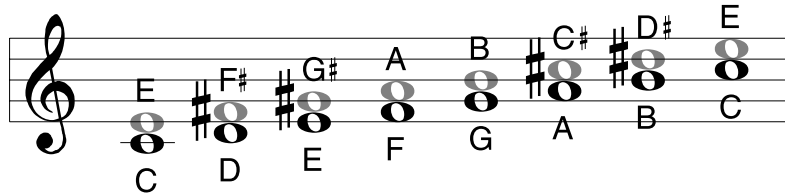

The sharps show the non-scale notes. The reason for the difference is that the chromatic harmony notes stay exactly 4 semitones (a major 3rd) above each scale note. In the diatonic example, the harmony notes varied between 3 and 4 semitones in order to stay true to the scale. The drawing below demonstrates this.

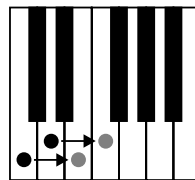

Diatonic

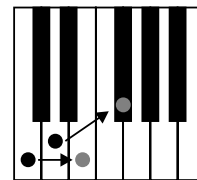

Chromatic

Scalic and Chordal Harmony; The Difference

Probably the toughest part of understanding harmony is pinpointing the difference between the Scalic and Chordal harmony types. There are many of each type of preset in the Studio Vocalist EX that, by trial and error, you have found useful yet not fully understood why. Let's try to clear that up.

The practical difference could be summed up in a couple of sentences:

1. Scalic Harmony usually requires you to enter the one key that works for a whole song. Scalic harmonies will sound correct in many songs but not all and this is why you have a choice between the two. Scalic harmonies are also more active in harmony motion.
2. Chordal harmony requires you to input a different chord change for every chord in a song. They can be applied to almost any song you can play.

This is only the practical difference between the two harmony types, we now need to explore the theoretical differences.

The word “scalic” has at its root the word “scale” and this is important. To the Studio Vocalist EX, a scale is:

a group of notes within one octave that falls in one of the following scale types; Chromatic, Major, Minor, Harmonic Minor, Melodic Minor, Wholetone, Diminished, Dorian and “Blues”.

In the previous example showing the principle of diatonic harmony, we were showing a scalic harmony. That is, one whose harmony notes only fall within the notes that belong to that particular scale. For our C major scale, this means there are 7 possible harmony notes.

This is a key part of the difference between Scalic and Chordal harmonies because for every note you sing in a Chordal harmony, the Studio Vocalist EX will choose from only three or four possible harmony notes.

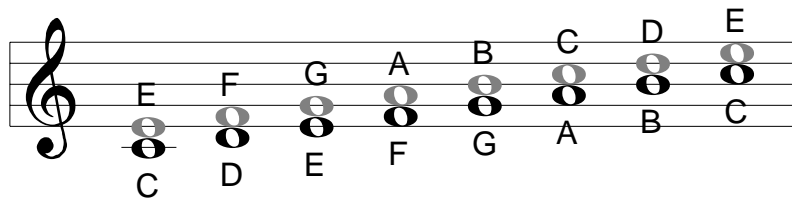

Scalic Harmony over C Major Scale

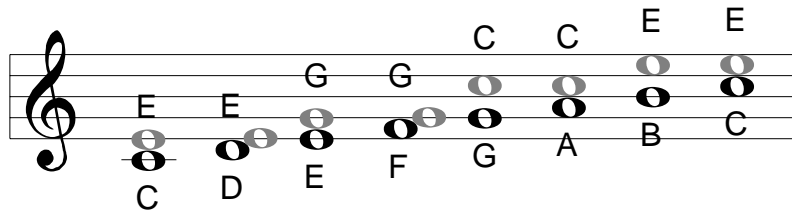

Chordal Harmony over C Major Scale

These fall within the notes of designated chords and are mostly made up of the root note, third, fifth and, optionally, the seventh of a chord. These are the choices that the Studio Vocalist EX has from which to produce a Chordal harmony. The following graphic shows where the harmony notes would fall in a simple 1 voice above Scalic and Chordal harmony.

Notice that in the Chordal example, the harmony notes jump over larger distances and are made of only the root, third and fifth of the scale.

The reason for using these different harmony types is that they create a more interesting musical experience. Most songs could benefit from either or both approaches. Depending on the chord changes in the accompaniment, the tight and always moving Scalic harmonies might be better for a catchy chorus where the more stationary and open Chordal harmonies would leave “breathing space” to highlight a lead vocal.

It is helpful to experiment with both of these harmony modes in all of the styles of music you enjoy.

SPECIFICATIONS

Microphone Input	Balanced XLR, 1 KOhm impedance, cardioid (directional) type preferred
Line Input	Balanced or unbalanced 1/4" TRS, +/-10 dB level (switchable), 10 KOhm impedance
Microphone Input Range	@ 150 Ohm source impedance: minimum -35 dBu, maximum +1.5 dBu
Line Input Range	Balanced input @ 50 Ohm source impedance: maximum +14.0 dBu
Line Outputs	Balanced or unbalanced 1/4" TRS, stereo or mono, +4 dBu (can be reduced by trimming Output Level fader) Maximum output level +24 dBu @ .03% THD
Sampling	A/D: 18 bit @ 48 KHz
Frequency Response (dry)	15 Hz to 20 KHz, +/-1 dB
Signal to Noise	>95 dB "A" weighted, auto gate engaged
Total Harmonic Distortion + Noise	<0.025%
Size	3.25" H x 19" W x 6.75" D 83 mm H x 483 mm W x 171 mm D
Weight	8.15 lb. 3.7 kg.
Internal Lithium Battery	Sony CR2032 Note: The lithium battery in the Studio Vocalist EX keeps a portion of the memory powered to retain user settings. If you find that user programs or songs cannot be stored, or are lost when the Studio Vocalist EX is turned off, this may be due to a dead battery. Take the Studio Vocalist EX to a DigiTech dealer or service centre to have the battery replaced. In normal use, a battery should last three to five years.

Specifications subject to change without notice

MIDI Implementation Chart

IVL Technologies Ltd.
Studio Vocalist EX

Date: February 1998
Version: 1.00

Function		Transmitted	Recognised	Remarks
Basic Channel	Default Changed	1-4 1-16	1-4 1 - 16	memorized
Mode	Default Messages Altered	X X *****	Mode 3 X	
Note Number	True Voice	0-127 *****	0-127 10-102	Key&Harmony Select, Vocoder and Pitch Correct, Song Step Vocoder and Pitch Correct
Velocity	Note On Note Off	X X	O X	Vocoder Scooping
After Touch	Polyphonic (Key's) Monophonic (Channel)	X X	X O	CC Assignment Map *1
Pitch Bender		X	O	Up to +/-12 Semitones
Control Change	0-15, 20-63, 65-119 16 17 18 19 64	X O O O X X	O O O O X O	CC Assignment Map *1 Key&Harmony Select Song Step Forward Song Step Backward Reserved for Future Use Damper Pedal
Program Change		0-127	0-127	Mappable
System Exclusive		O	O	See details on following pages
System Common	Song Position Song Select Tune Request	X O X	X O X	Mappable
System Real Time	Clock Commands	X X	X X	
Aux Messages	Local On/Off All Notes Off Active Sensing System Reset	X X X X	X X X X	Chord Recognition, Vocoder and Pitch Correct
Notes	*1: Channel Pressure and CC's 0-15, 20-63, 65-119 are available for mapping to control volume, detune, vibrato depth, vibrato rate and harmony hold.			

Mode 1: OMNI ON, POLY
Mode 3: OMNI OFF, POLY

Mode 2 : OMNI ON, MONO
Mode 4 : OMNI OFF, MONO

O : YES
X : NO

MIDI MESSAGES

MIDI PARAMETER EDIT

format:	<i>Example:</i>
procedure number 60h	60
effect number	01
style number	01
parm number	01
value MSB (0,0,0,0,0,value lo.7,value hi.7)	00
value hi (6-0 bits)	00
value lo (6-0 bits)	10

Example:

F0 00 00 10 00 37 60 01 01 01 00 00 10 F7
; parm edit effect 1, detune, parm 1, Packed value

MIDI SysEx Message Format:

F0 00 00 10 00 37 60 01 01 01 **00 00 10** F7
Universal DOD SysExStudio _____ Value _____
End
SysEx Manuf. Chan- Vocallist Parm of
Header ID nel EX ID Edit Message

MIDI QUERY: QUERY

format:
procedure number 5Eh
query type (0=front panel, 1=edit buffer)

Example:

F0 00 00 10 00 37 5E 00 F7; SYSEX query (front panel)
F0 00 00 10 00 37 5E 01 F7; edit buffer

MIDI QUERY: RESPONSE

format depends on the query type

format (front panel) :

procedure number 5Dh
PACKED {
query type (0=front panel)
data size hi (00h)
data size lo (56h)
character set (1 byte)
LCD buffer (80 bytes)
levels
.7-.4 return levels
.7-.4 input levels
LED state (2 bytes)
.1=bypass
.2=factory
.3=user
.4=song
.5=utility

.6=edit

}

format (edit buffer) :

procedure number 5Dh
PACKED {
query type (1=edit buffer)
data size hi
data size lo
data
}

Example:

F0 00 00 10 00 37 5D ... packed data ... F7 ; SYSEX query response

DEVICE INQUIRY: QUERY

format:
procedure number 7Eh (universal system exclusive non real time header)
channel number xx (with 7FH, device responds no matter what sys chan)
general info id 06
device inquiry message id 01

Example:

F0 7E 7F 06 01 F7

DEVICE INQUIRY: RESPONSE

format:
procedure number 7Dh (universal system exclusive non real time header)
channel number xx
general info id: 06
device id response message: 02
manufactures id: 00 00 10 (DOD Electronics)
device family code (24h,00)
device member code (00, 00)
software version id (integer, fraction, 0, 0)

Example:

F0 7E xx 06 02 00 00 10 24 00 00 00 01 00 00 00 F7 ;
Studio Vocalist EX 1.0

MIDI EDIT BUFFER EDIT

format:

```
procedure number 5Ch
PACKED {
edit buffer data
}
```

Example:

F0 00 00 10 00 37 5C ... packed edit buffer data ... F7 ; edit buffer edit

MIDI KEY PRESS

format:

```
procedure number 5Fh
switch type
(4=switch, 5=control abs, 6=control inc, 7=control dec)
switch number
value (7th bit)
value (6-0 bits)
```

Example:

F0 00 00 10 00 37 5F 06 04 00 01 F7 ; rotenc inc 1

F0 00 00 10 00 37 5F 04 14 00 01 F7 ; edit on

F0 00 00 10 00 37 5F 05 03 00 00 F7 ; soft key 0

PACKED BYTES OPERATION:

MIDI data is transmitted in a packed data format. The packing format groups the 8-byte data into 7 bytes. The most significant bits of the next 7 data bytes are sent first then the 7 bytes with the most significant bit removed are sent. On receiving the data, the data can be retrieved by combining the most significant bit with the corresponding lower bits.

MIDI sysex data format reserves the most significant bit to indicate status bytes.

Sending data via MIDI sysex must clear the most significant bit, but this changes the data value, so the data must be packed so information is not lost.

byte 1 : MSB byte

data 1 bit 7 in msb.0

data 2 bit 7 in msb.1

data 3 bit 7 in msb.2

data 4 bit 7 in msb.3

data 5 bit 7 in msb.4

data 6 bit 7 in msb.5

data 7 bit 7 in msb.6

byte 2 : data 1 byte (6-0 bits)

byte 3 : data 2 byte (6-0 bits)

byte 4 : data 3 byte (6-0 bits)

byte 5 : data 4 byte (6-0 bits)

byte 6 : data 5 byte (6-0 bits)

byte 7 : data 6 byte (6-0 bits)

byte 8 : data 7 byte (6-0 bits)

Example:

To represent the value 131, convert to hexadecimal (hex)

131 decimal = 0083 hex *

Group the hex value into two pairs: 00 83

Translate each number into binary

0,0 hex = 0000,0000 binary 8,3 hex = 1000,0011 binary

result: 0000,0000 1000,0011

Remove the most significant bits (MSB) - the leading numerals - and make them zeros

result: 0000,0000 0000,0011 removed 0 & 1

Convert back to hex - result: 00, 03

Take the MSBs that were removed, (0 and 1 in this example) and put them into binary byte:

result: 0000,0001 Convert to hex - result: 01

Add this byte before the other two

Final result: 131 decimal = 01,00,03 packed

Example 2:

To represent the value -50, convert to hexadecimal (hex)

-50 decimal = FFCE hex

Group the hex value into two pairs: ff ce

Translate each number into binary

F,F hex = 1111,1111 binary C,E hex = 1100,1110 binary

binary result: 1111,1111 1100,1110

Remove the most significant bits (MSB) - the leading numerals - and make them zeros

result: 0111,1111 0100,1110 removed 1 & 1

Convert back to hex - result: 7F, 4E

Take the MSBs that were removed, (1 and 1 in this example) and put them into binary byte:

result: 0000,0011 Convert to hex - result: 03

Add this byte before the other two

Final result: -50 decimal = 03,7F,4E packed

* Note: The Calculator applet included with Microsoft

Windows has Hex conversion functions.

MIDI SYSEX Dump 1 Studio Vocalist EX Program Formats

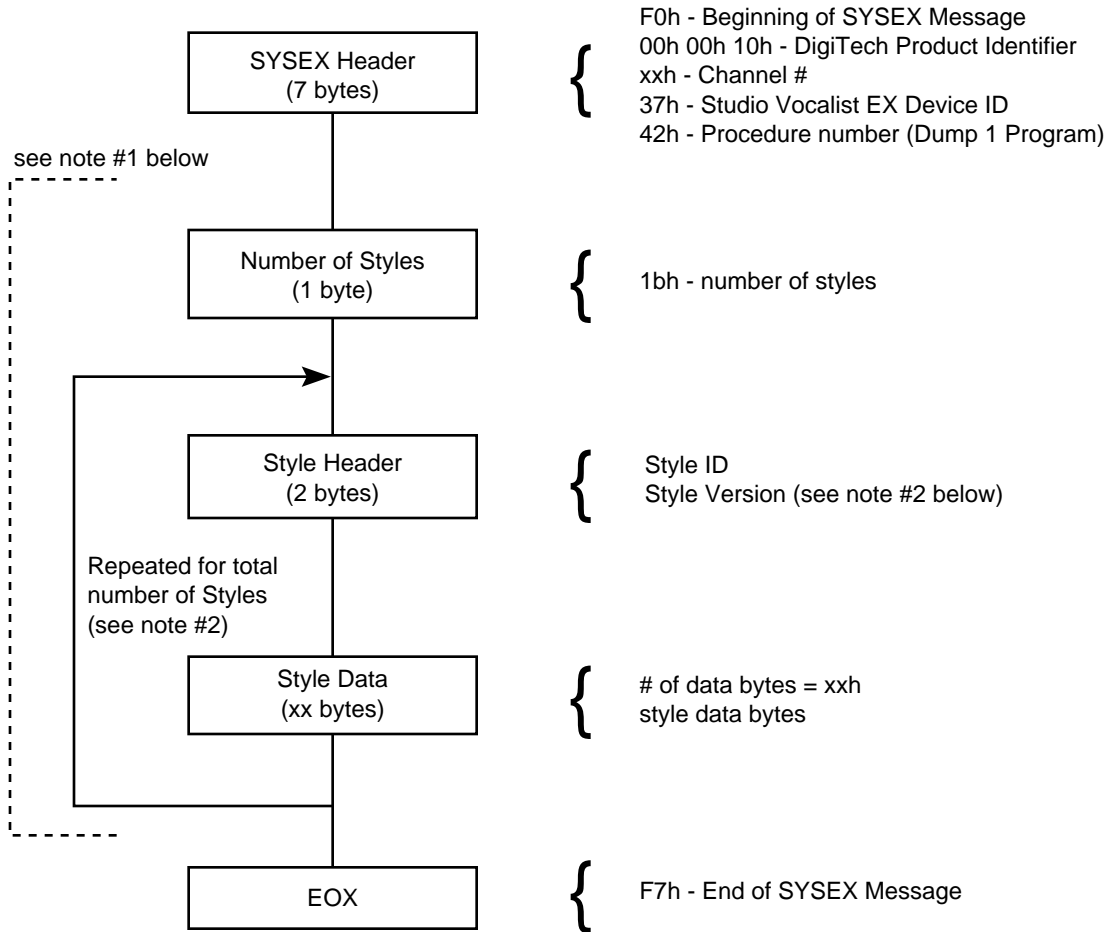

NOTES:

1) The data enclosed by the dotted line is transmitted in 8 / 7 bit-packed format, e.g. MSbits byte followed by $n \leq 7$ data bytes with MSbits cleared.

2) Dump 1 Style List Order:

PS4preset style	custharmony style
PS4EFFECT style	variation style
detune style	custharmony style
vibrato style	variation style
time style (time OFF)	custharmony style
scoop style	variation style
mix style	custharmony style
timbre style	variation style
variation style	custharmony style
custharmony style	
variation style	
custharmony style	
variation style	
custharmony style	
variation style	

MIDI SYSEX Dump All Studio Vocalist EX Program Formats

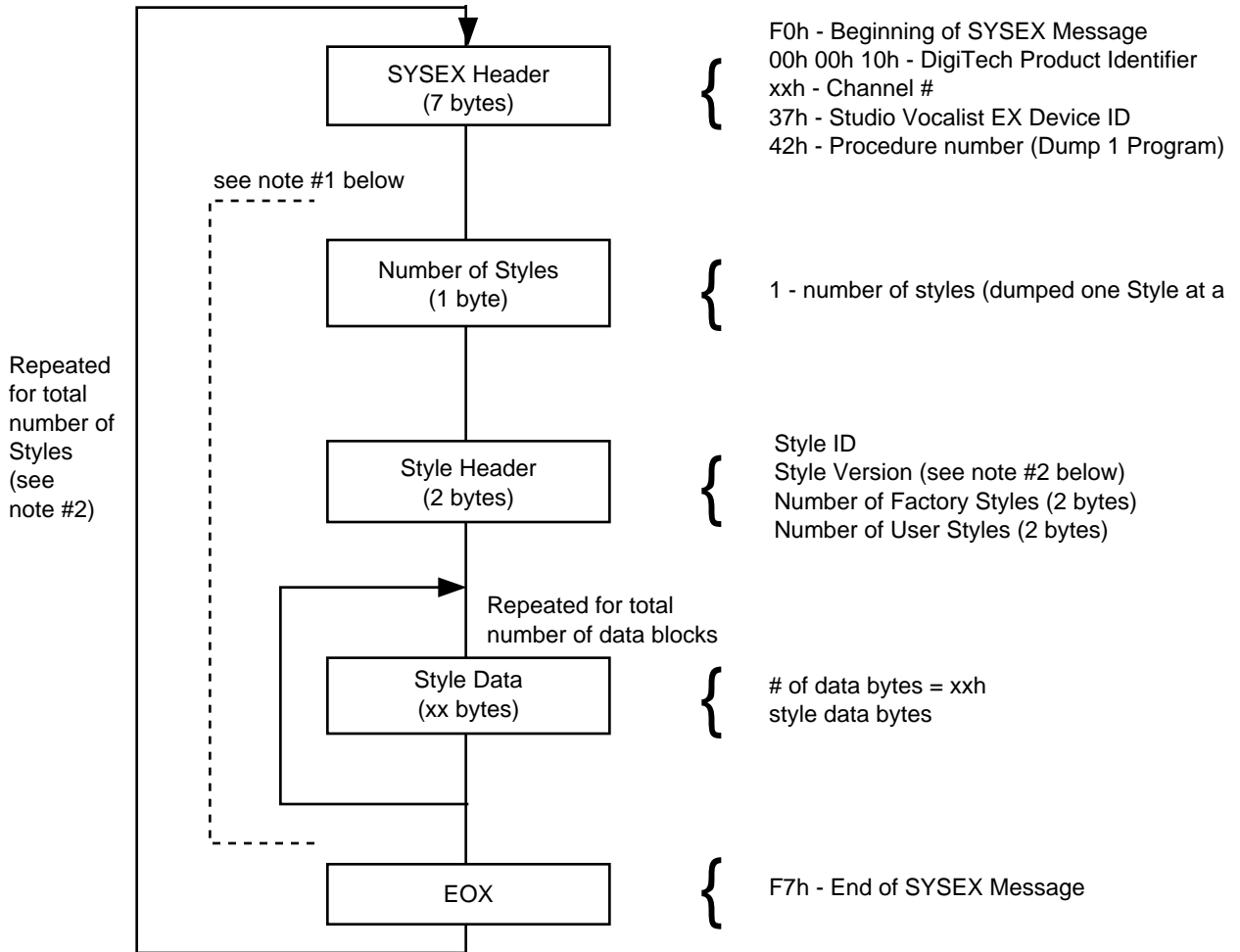

NOTES:

1) The data enclosed by the dotted line is transmitted in 8 / 7 bit-packed format, e.g. MSbits byte followed by $n \leq 7$ data bytes with MSbits cleared.

2) Dump All Programs Style Order:

PS4preset style
PS4EFFECT style
detune style
variation style
cutharmony style
vibrato style
time style
timbre style
scoop style
mix style

MIDI Sysex Parameters

PARAMETER EDITS

PROGRAM EFFECT STYLE: (EFFECT: 1 STYLE: 0)

0 detune index	0 to 16
1 vibrato index	0 to 20
2 protected	
3 scoop index	0 to 17
4 protected	
5 gender index	0 to 50
6 variation 0 index	0 to 381 (2 bytes)
7 variation 1 index	0 to 381 (2 bytes)
8 variation 2 index	0 to 381 (2 bytes)
9 variation 3 index	0 to 381 (2 bytes)
10 variation 4 index	0 to 381 (2 bytes)
11 variation 5 index	0 to 381 (2 bytes)
12 variation 6 index	0 to 381 (2 bytes)
13 variation 7 index	0 to 381 (2 bytes)

DETUNE STYLE: (EFFECT: 1 STYLE: 1)

0	protected
1 amount 0	-100 to 100
2 amount 1	-100 to 100
3 amount 2	-100 to 100
4 amount 3	-100 to 100
5 random 0	0 to 25
6 random 1	0 to 25
7 random 2	0 to 25
8 random 3	0 to 25
9 pitch randomize	0=off, 1=low, 2=med, 3=high

VIBRATO STYLE: (EFFECT: 1 STYLE: 2)

0	protected
1 type 0	0=sine, 1=sqr, 2=saw 1, 3=saw 2
2 type 1	0=sine, 1=sqr, 2=saw 1, 3=saw 2
3 type 2	0=sine, 1=sqr, 2=saw 1, 3=saw 2
4 type 3	0=sine, 1=sqr, 2=saw 1, 3=saw 2
5 depth 0	0 to 100 (for 0 to +/- 100)
6 depth 1	0 to 100 (for 0 to +/- 100)
7 depth 2	0 to 100 (for 0 to +/- 100)
8 depth 3	0 to 100 (for 0 to +/- 100)
9 rate 0	0 to 99 (for 0 to 9.9)
10 rate 1	0 to 99 (for 0 to 9.9)
11 rate 2	0 to 99 (for 0 to 9.9)
12 rate 3	0 to 99 (for 0 to 9.9)

13 delay 0	0 to 250 (for 0 to 2.50)
14 delay 1	0 to 250 (for 0 to 2.50)
15 delay 2	0 to 250 (for 0 to 2.50)
16 delay 3	0 to 250 (for 0 to 2.50)
17 random 0	0 to 10
18 random 1	0 to 10
19 random 2	0 to 10
20 random 3	0 to 10

SCOOP STYLE: (EFFECT: 1 STYLE: 4)

0	protected
1 rate 0	0 to 10
2 rate 1	0 to 10
3 rate 2	0 to 10
4 rate 3	0 to 10
5 amount 0	0 to 90 (for 0 to 900)
6 amount 1	0 to 90 (for 0 to 900)
7 amount 2	0 to 90 (for 0 to 900)
8 amount 3	0 to 90 (for 0 to 900)
9 scoop occurrence	0 to 100
10 velocity threshold	0 to 127, -1=off

MIX STYLE: (EFFECT: 1 STYLE: 5)

0 wet	0 to 100
1 dry	0 to 100
2 voice	0 -40 to 0, -41=off
3 voice	1 -40 to 0, -41=off
4 voice	2 -40 to 0, -41=off
5 voice	3 -40 to 0, -41=off
6 pan 0	0 to 100
7 pan 1	0 to 100
8 pan 2	0 to 100
9 pan 3	0 to 100
10 pan dry	0 to 100
11 aux 0	-40 to 0, -41=off
12 aux 1	-40 to 0, -41=off

GENDER STYLE: (EFFECT: 1 STYLE: 6)

0	protected
1 assign 0	0 to 1 (for 1 to 2)
2 assign 1	0 to 1 (for 1 to 2)
3 assign 2	0 to 1 (for 1 to 2)
4 assign 3	0 to 1 (for 1 to 2)
5 TIMBRE shift 0	-50 to 50
6 TIMBRE shift 1	-50 to 50

VARIATION STYLE: (EFFECT: 1 STYLES: 7-14)

Style 7 = Variation 0 Style 8 = Variation 2
and so on up to Style 14 = Variation 7

0	protected
1 harmony type	0=Chromatic, 1=Scalic, 2=Chordal, 3=Vocoder, 4=PitchCorr
2	protected
3 scale type	0=Major, 1=Minor, 2=Whole, 3=Dimin, 4=Blues, 5=Dorian, 6=HarMin, 7=MelMin
4 chord type	0=maj, 1=maj7, 2=min, 3=min7, 4=dom7, 5=m7b5, 6=dim7, 7=aug7, 8=sus, 9=sus7
5 interval 0	1 to maximum valid interval
6 interval 1	1 to maximum valid interval
7 interval 2	1 to maximum valid interval
8 interval 3	1 to maximum valid interval
9 chordal harm motion	0=normal, 1=fixed
10 smooth bend	0=smooth, 1=stepped
11 pitch bend range	0 to 12 (for 0 to +/- 12)
12 vocoder mode	0=1 Voice, 1=1 Voice Layered, 2=2 Voice, 3=2 Voice Layered, 4=3 Voice, 5=4 Voice, 6=4 MIDI Channels
13 vocoder transpose octave	-3 to 3, 4 auto
14 portamento rate	0 to 10

GLOBAL STYLE: (EFFECT: 15 STYLE: 0)

0	protected
1	protected
2	protected
3	protected
4	protected
5 KeyRoot (C)	0 to 11
6	protected
7 bypass (off)	0=ON, 1=OFF
8	protected
9 interval display type	0=Notes, 1= SemiTones
10	protected
11	protected
12	protected
14 lcd contrast	0 to 7, 7=High
15	protected
16 timbre split point	128 to 129
17 MIDI KVS channel	0 to 15, 16=omni, 17=off
18 MIDI system channel	0 to 15, 16=omni, 17=off
19 MIDI Voc channel 2	0 to 15, 16=omni, 17=off
20 MIDI Voc channel 3	0 to 15, 16=omni, 17=off
21 MIDI Voc channel 4	0 to 15, 16=omni, 17=off
22 MIDI current CCmap idx	0=volume, 1=detune, 2=vibdepth, 3=vib rate, 4=harmhold

23 MIDI current CCparm	0 to 15, 20 to 119, 120=aftertouch, 121=none
24 MIDI current CCpol	0=, 1=+
25 MIDI KVS mode	0=program change, 1=notes, 2=chords and CC 16
26 MIDI KVS comm	0=off, 1=receive, 2=transmit, 3=receive + transmit
27 MIDI KVS splitdir	0=below, 1=above
28 MIDI KVS splitpoint	0 to 127
29 MIDI current PCmap idx	0 to 127
30 MIDI current PCprog	0 to 197, 198=bypass, 199=none
31 MIDI current PCprog name	0..197
32 MIDI PC comm	0=off, 1=receive, 2=transmit, 3=receive + transmit
33 MIDI current SSmap idx	0 to 127
34 MIDI current SSsong	0 to 127, 128=none
35 MIDI current SSsong name	0 to 127
36 MIDI SS comm	0=off, 1=receive, 2=transmit 3=receive + transmit
37 MIDI SongStep fwd	-1=CC 17, 0 to 127
38 MIDI SongStep back	-1=CC 18, 0 to 127
39 MIDI SongStep comm	0=off, 1=receive, 2=transmit, 3=receive + transmit
40 MIDI Voc splitdir	0=below, 1=above
41 MIDI Voc splitpoint	0 to 127
42 AUDIO harm gate	-60=off, -59 to -20
43 AUDIO bass reject	1 to 10
44 AUDIO ess sens	1 to 10
45 AUDIO feedback	1 to 10
46 AUDIO tuningref	-100 to 100
47 AUDIO synthmode	0=OFF, 1=ON-25
47 AUDIO synthmode	0=OFF, 1=ON
48 AUDIO synthvolume	-24 to 0
49	protected

continued next page...

50 USER uservoicedit	0=OFF, 1=ON
51 USER footsw1	0=BypL, 1=BypM, 2=Pgm down, 3=Pgm up, 4=Sng down, 5=Sng up, 6=Stp down, 7=Stp up, 8=Dat down, 9=Dat up
52 USER footsw2	0=BypL, 1=BypM, 2=Pgm down, 3=Pgm up, 4=Sng down, 5=Sng up, 6=Stp down, 7=Stp up, 8=Dat down, 9=Dat up
53 USER footsw3	0=BypL, 1=BypM, 2=Pgm down, 3=Pgm up, 4=Sng down, 5=Sng up, 6=Stp down, 7=Stp up, 8=Dat down, 9=Dat up
54	protected
55 custharmony interval 0	1 to maximum valid interval
56 custharmony interval 1	1 to maximum valid interval
57 custharmony interval 2	1 to maximum valid interval
58 custharmony interval 3	1 to maximum valid interval
59	protected
60	protected
61	protected
62	protected
63	protected
64	protected
65	protected
66	protected
67	protected
68	protected
69	protected
69	protected
70	protected
71	protected
72	protected
73	protected

BUTTON PRESS

switch	4	for key press which are on/off values
control absolute	5	for key press with a value
control relative inc	6	for key press with a relative increment value
control relative dec	7	for key press with a relative decrement value

CONTROLLER SWITCHES AVAILABLE THRU MIDI SYSEX

1 NOTE KEY	use controller absolute and note key values
2 ARROW	controller increment (right arrow) controller decrement (left arrow)
3 SOFT	use controller absolute and soft key values
4 ROTENC	use controller increment / decrement
10 SUNGNOTE	use controller absolute and note key values

SWITCHES WHICH ONLY HAVE ON/OFF VALUES

16	BYPASS KEY
17	BYPASS KEYM
18	STORE
19	EXIT
20	EDIT
22	SONG
23	UTILITY
28	FACTORY
29	USER

NOTE KEY VALUES

0	C
1	C#
2	D
3	D#
4	E
5	F
6	F#
7	G
8	G#
9	A
10	A#
11	B

SOFT KEY VALUES

in the order they appear

0	2	4	6
1	3	5	7

Decimal / Hexadecimal / Binary Table

Decimal	Hexadecimal	Binary
0	0	0000
1	1	0001
2	2	0010
3	3	0011
4	4	0100
5	5	0101
6	6	0110
7	7	0111
8	8	1000
9	9	1001
10	A	1010
11	B	1011
12	C	1100
13	D	1101
14	E	1110
15	F	1111
16	10	0001,0000
17	11	0001,0001
18	12	0001,0010
19	13	0001,0011
20	14	0001,0100
21	15	0001,0101
22	16	0001,0110
23	17	0001,0111
24	18	0001,1000
25	19	0001,1001
26	1A	0001,1010
27	1B	0001,1011
28	1C	0001,1100
29	1D	0001,1101
30	1E	0001,1110
31	1F	0001,1111
32	20	0002,0000
33	21	0002,0001
34	22	0002,0010
35	23	0002,0011
36	24	0002,0100
37	25	0002,0101
38	26	0002,0110
39	27	0002,0111
40	28	0002,1000

Decimal / Hexadecimal Packed Bytes Table

Decimal	Hexadecimal	Packed
-100	FF9C	03 7F 1C
-50	FFCE	03 7F 4E
-25	FFE7	03 7F 67
-10	FFF6	03 7F 76
-5	FFFB	03 7F 7B
-2	FFFE	03 7F 7E
-1	FFFF	03 7F 7F
0	0000	00 00 00
1	0001	00 00 01
2	0002	00 00 02
5	0005	00 00 05
10	000A	00 00 0A
25	0019	00 00 19
50	0032	00 00 32
100	0064	00 00 64
150	0096	01 00 16
200	00C8	01 00 48



**8760 South Sandy Parkway
Sandy, Utah, 84070**

**Telephone (801) 566-8800
Fax (801) 566-7005**

**International Distribution: 7 Farmington Road
Amherst, New Hampshire 03031 U.S.A.
Fax (603) 672-4246**

**DigiTech is a registered trademark of DOD
Electronics Corporation**

**Copyright 1998
DOD Electronics Corporation**

Studio Vocalist EX VERSION 1.10 Mar 02/98

18-2110-C